



HD5200

Half Mortise Continuous Geared Hinge

PRODUCT CUT SHEET

PROJECT:

SUBMITTED BY:

DATE:

NOTES:

NO DOOR INSET, FLUSH MOUNT FOR 1 3/4" DOORS

- ▶ Aluminum Alloy 6063-T6; Anodized After Machining
- ▶ Specially Designed Involute Intermeshing Gears
- ▶ Proprietary Teflon Infused Self-Lubricating Wear-Resistant Bearings
- ▶ No Hinge Reinforcement Necessary Except on Extremely Heavy, Extremely High-Frequency or Extra-Wide Doors
- ▶ Lifetime of the Door Opening Warranty
- ▶ #12-24 TEK MS
- ▶ Standard Lengths: 83", 85", 95", 119"

Options:

- ▶ #12 x 1 1/2" Wood Screws
- ▶ Torx Security TEK Screws
- ▶ 1 1/2" Torx Security Wood Screws
- ▶ Cut to Net Length - Specify Door Handing
- ▶ Anti-Ligature Hospital Tip - Specify "TIPIT-LG"
- ▶ Dutch Door Prep - Order Form Available at ngp.com
- ▶ EPT Prep - Order Form Available at ngp.com

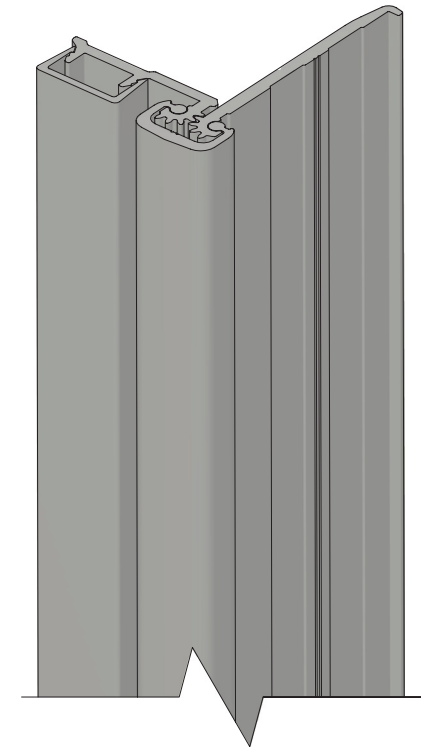
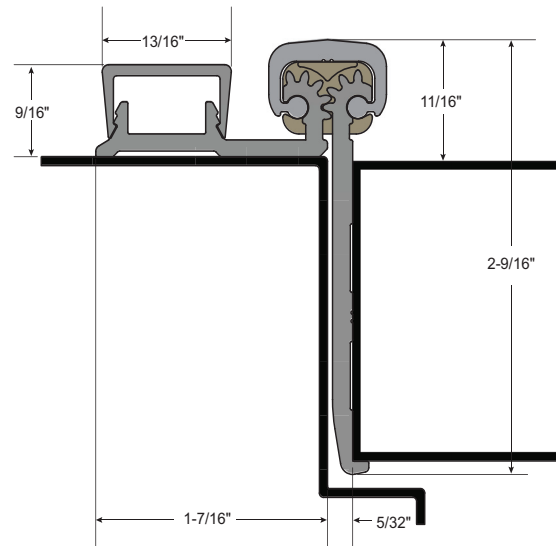

Finishes:

- A - Anodized Aluminum
- DKB - Dark Bronze Anodized



Fire-rated 90 minute on hollow metal (except steel stiffened) or wood door leaves up to 4'0" x 7'2".



ANSI/BHMA Certified to A156.26 American National Standard for Continuous Hinges: Grade 1 - 600 lb. Door

Note: For Door Sizing Refer to Installation Instruction.

NGP-CHG-HD5200-PCS-1224-A

NATIONAL GUARD PRODUCTS, INC.

MEMPHIS

4985 East Raines Road
Memphis, TN 38118

CARSON CITY

3689 Arrowhead Drive
Carson City, NV 89706

Fax: (800) 255-7874

Email: info@ngp.com

Quotes: quotes@ngp.com

Orders: orders@ngp.com

ngp.com
1-800-NGP-RUSH