

# CONTINUOUS GEARED HINGE

## CONCEALED

1/8" DOOR INSET, FOR 1 3/4" DOORS

### HD1800 HD1800-LL

Continuous geared aluminum hinges run the full height of the door evenly distributing the weight of the door along the full height of the frame. Ideal for high-frequency and heavy-weight doors in new construction and retrofit applications.

- Aluminum alloy 6063-T6; Anodized after machining
- Specially designed involute intermeshing gears
- Proprietary Teflon infused self-lubricating wear resistant bearings
- No hinge reinforcement necessary except on extremely heavy, extremely high-frequency or extra-wide doors
- Lifetime of the door opening warranty
- #12-24 TEK MS
- "LL" model for doors up to 1,000 lbs. features lead-lined dual row hole pattern
- Standard lengths: 83", 85", 95", 119"

#### Available Options:

- #12 x 1 1/2" Wood Screws
- Torx Security TEK Screws
- 1 1/2" Torx Security Wood Screws
- Cut to Net Length - Specify Door Handing
- Anti-Ligature Hospital Tip - Specify "ALHT" and Door Handing
- Dutch Door Prep - Specify Door Handing, Top Door Leaf Length, and Clearance Between Leafs

#### Finishes:

- A - Anodized Aluminum
- DKB - Dark Bronze Anodized



Fire-rated 90-minute on hollow metal (except steel stiffened) or wood door leafs up to 4'0" x 8'0" and steel stiffened doors up to 4'0" x 7'2".



ANSI/BHMA Certified to A156.26 American National Standard for Continuous Hinges:  
Grade 1 - 150 lb. Door  
Grade 1 - 600 lb. Door

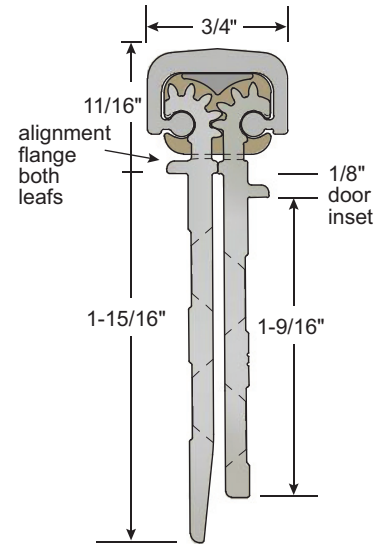

Frame leaf covers butt hinge preps

