



92T

Thermoplastic Extended Door Shoe

PRODUCT CUT SHEET

| |
|---------------|
| PROJECT: |
| SUBMITTED BY: |
| DATE: |
| NOTES: |

Material

Aluminum Alloy 6063, T5 Temper
Thermoplastic polymer: Polyvinyl Chloride (PVC) Formulated with an Environmentally Friendly Bio-Based Plasticizer
Seal with Rigid Base and Soft Vinyl Fins is Dark Brown

- ▶ Economical
- ▶ Flame Resistant
- ▶ Moisture Resistant
- ▶ Temperature Range 0°F to 140°F
- ▶ Oxidative Degradation from Age and Exposure to Cold, Heat and UV Causes Hardening, Loss of Memory and Resilience, Cracking, Crazeing and Discoloration
- ▶ #6 x 3/4" Stainless Steel SMS Furnished
- ▶ End Caps Available - Sold Separately

Finishes

92TA Anodized Aluminum
92TDKB Dark Bronze

Option

Notched Fins - Suffix "NF"

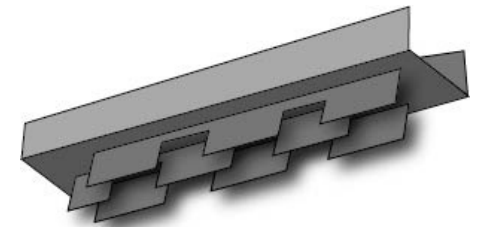
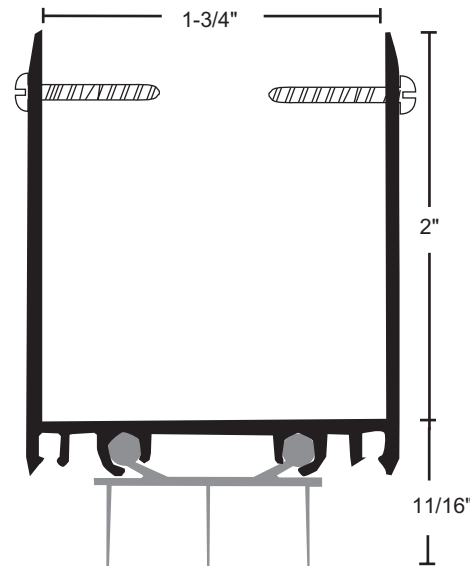

Optional: Notched Fins - Suffix "NF"
Allows air flow while restricting light.



NGP-GKT-92T-PCS-1220-A