



# 120N

## NEOPRENE CLOSED CELL SPONGE SEAL

### PRODUCT CUT SHEET

PROJECT:
SUBMITTED BY:
DATE:
NOTES:

#### Material

Aluminum Alloy 6063, T5 Temper  
Synthetic Rubber Polymer Blend: PVC, Nitrile Rubber (NBR), and Chloroprene Closed Cell Advanced Elastomeric Foam  
Neoprene is Black

- ▶ Very Good Abrasion Resistance, Tensile Strength and Memory
- ▶ Flame Resistant
- ▶ Moisture Resistant
- ▶ Temperature Range -20°F to 200°F
- ▶ Good Resistance to Ozone, Sunlight and Aging
- ▶ BHMA Certified to ANSI/BHMA A156.22 Performance Tests for Heat and Cold
- ▶ #6 x 3/4" Stainless Steel Sheet Metal Screws Furnished
- ▶ Screw Holes Slotted for Adjustment

#### Finishes

120NA Anodized Aluminum  
120NB Gold  
120NDKB Dark Bronze

#### Options

FATT - Fast Attach Tape

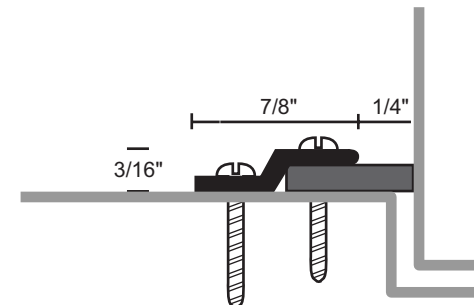

NGP-GKT-120N-PCS-0720-A