



103N

Adjustable Neoprene Perimeter Seal

PRODUCT CUT SHEET

PROJECT:
SUBMITTED BY:
DATE:
NOTES:

Material

Aluminum Alloy 6063, T5 Temper
Synthetic EPDM Rubber in Polypropylene Thermoplastic Matrix
Closed Cell Advanced Elastomeric Foam
Color is Black

- ▶ Very Good Abrasion Resistance, Tensile Strength and Memory
- ▶ Flame-Resistant
- ▶ Moisture-Resistant
- ▶ Temperature Range -81°F to 275°F
- ▶ Good Resistance to Ozone, Sunlight and Aging
- ▶ BHMA Certified to ANSI/BHMA A156.22 Performance Tests for Heat and Cold
- ▶ Adjustment Screws on 10" Centers Allow Adjustment Without Re-Positioning Mounting Location
- ▶ #6 x 3/4" or #6 x 1 1/2" Stainless Steel SMS Furnished

Finishes

103NA Anodized Aluminum
103NDKB Dark Bronze

Options

- ▶ FATT - Fast Attach Tape
- ▶ Foam Back Seal - suffix 'FS'

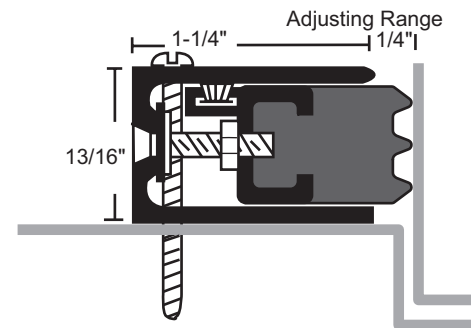

NGP-GKT-103N-PCS-1223-A

NATIONAL GUARD PRODUCTS, INC.

MEMPHIS

4985 East Raines Road
Memphis, TN 38118

CARSON CITY

3689 Arrowhead Drive
Carson City, NV 89706

Fax: (800) 255-7874
Email: info@ngp.com

Quotes: quotes@ngp.com
Orders: orders@ngp.com

ngp.com
1-800-NGP-RUSH