



— CONDENSED —
CATALOG



— IT'S NOT "JUST" —
BUSINESS
— WITH NGP, IT'S —
PERSONAL

IN A MARKET FULL OF MERGERS AND CORPORATE RED TAPE, NGP STANDS APART. WE'RE STILL INDEPENDENT. STILL FAMILY-RUN. STILL ANSWERING TO OUR CUSTOMERS — NOT WALL STREET.

We've never believed in being "just" a manufacturer. Products matter — but people matter more. That's why our team is built on service, trust, and relationships that last. For 90 years, we've grown by listening. Every conversation we have with you shapes the way we do business. Your challenges become our opportunities. Your ideas become our priorities. That's why, after nearly a century, our mission is the same as day one: put the customer first, every single time.

Because at the end of the day, we're more than a manufacturer.

We're your partner. Your problem-solver. Your team.

THE TEAM • THE PRODUCTS
THE SERVICE



No robots allowed!
We pride ourselves on an exceptional level of service.



We're closer to you than ever before and ready to fill your order!



Some of our most popular products and sizes - shipped from our Carson City Facility!



Stop wasting your time with the other guys and start trusting your Division 8 provider.

— FEATURING OUR —
PRODUCT CATEGORIES

SEALS

Thresholds
Gasketing
Door Bottoms



LITES

Lite Kits
Louvers

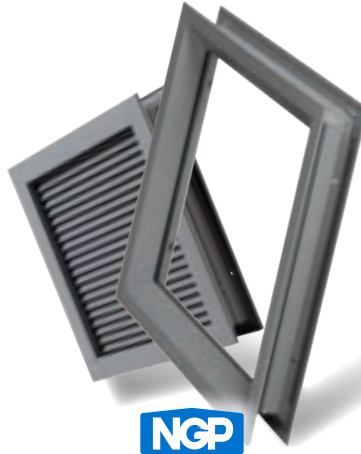

GLASS

Fire
Safety
Specialty

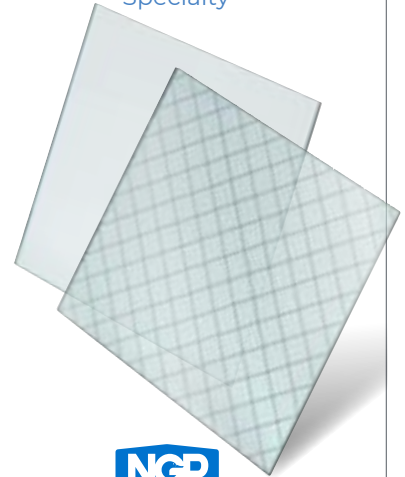

HINGE

Aluminum
Continuous Geared
Stainless Steel
Pin & Barrel



SLIDING

Stainless Steel Barn Door Track
Aluminum Track Systems
Steel Flat Track



GAPGUARD

Gap90
9590
9990





CONDENSED CATALOG INDEX

Bumper Seal Thresholds.....	5	Nylon Brush Seals with EPDM Rubber	14
Concealed Fastener Seals	10	Insert Perimeter Seals	11
Continuous Hinge, Aluminum Geared		Glass	22
Concealed	23	Half Saddle Thresholds	7
Full Surface	24	Heavy-Duty Thresholds	6
Half Surface	24	Hospitality	
Continuous Hinge, Stainless Steel		Door Bottoms, Door Shoes, Door Guards.....	18
Concealed	25	Security Door Guard.....	18
Full Surface	26	Vinyl Thresholds, Smoke Seal.....	17
Half Mortise	26	Lite Kits & Louvers	20-21
Swing Clear.....	26	Offset Saddle Thresholds	7
Cover Plates	6	Saddle Thresholds	5
Finger Guard	19	Self-Adhesive Gasketing	9
Flood Shield	19	Sliding Door Hardware	
GAPGUARD.....	31-32	By-Pass, Bi-Fold	27
Gasketing		By-Pass, Side Wall Mount	28
Adjustable Perimeter Seals.....	12	Pocket Door/Frame Kit.....	29
Astragals.....	12	Stainless Steel	30
Automatic Door Bottoms.....	13	Stainless Steel Saddle.....	8
Door Shoes	16	Thermal Break Thresholds.....	8
Door Sweeps	15		

NUMERICAL INDEX

12V.....	16	434.....	5	2248.....	19	HD5400.....	24
20T.....	22	435.....	5	2252.....	19	HD5700.....	24
36ET.....	18	436.....	5	5020.....	9	HP90-CYL.....	32
36ET6.....	16	437.....	5	5050.....	9	HP90-FB.....	32
97V.....	15	438.....	5	5070.....	9	HP90-MORT.....	32
101V.....	15	439.....	5	5075.....	9, 17	INSULATED	
103N.....	12	440.....	5	8424.....	8	TEMPERED GLASS.....	22
107.....	12	512SS.....	8	8425.....	8	L-CVFM-SS.....	20
110.....	11	513.....	5	8426.....	8	L-700-A.....	20
115N.....	12	513HD.....	6	8427.....	8	L-700-RX.....	20
137.....	11	513SS.....	8	8428.....	8	LAMINATED GLASS.....	22
155.....	11	A605.....	11	8429.....	8	L-FRA100.....	120
158.....	12	613.....	5	8430.....	8	LO-PRO.....	21
160.....	11	A626.....	11	9590.....	32	LO-PRO-IS.....	21
170.....	10	C627.....	15	9595DKB.....	32	PROTECT3™.....	22
172.....	10	653.....	7	9990.....	31	Pyran® Platinum F.....	22
200.....	15	659.....	7	AFDL.....	20	SDG.....	18
220.....	13	672.....	10	FDLS.....	21	SLAL-250-BP.....	28
319EV.....	16	675.....	10, 15	FS10.....	19	SLAL-250-PD.....	29
320.....	13	D690.....	14	FS22.....	19	SLAL-250-PDKIT.....	29
324.....	7	C697.....	14	FS34.....	19	SLAL-250-SW.....	28
325.....	7	D698.....	14	FSSP.....	19	SLAL-75-BF.....	27
335N.....	18	C699.....	12	GAP90.....	31	SLAL-75-BP.....	27
400.....	17	700.....	11	GAP90-ME.....	31	SLAL-75-BPF.....	27
401.....	17	713.....	5	GAP90N.....	31	SLSS1.....	30
413.....	5	813.....	5	GAPGUARD		SLSS2.....	30
420N.....	13	814.....	6	FIRE CAULK.....	32	SS300.....	25
423N.....	13	814SS.....	6	HD1100.....	23	SS302.....	26
424E.....	5	818.....	6	HD1400.....	23	SS304.....	26
425E.....	5	818SS.....	6	HD1800.....	23	SS305.....	25
425HD.....	6	838.....	6	HD2100.....	24	SS306.....	26
426E.....	5	896.....	5	HD2400.....	23	SS311.....	26
427E.....	5	896HD.....	6	HD2700.....	23	SS315.....	25
428E.....	5	913.....	5	HD4100.....	23	TEMPERED GLASS.....	22
429E.....	5	950.....	5	HD4200.....	24		
430E.....	5	1013.....	5	HD5300.....	24		

TECHNICAL INFORMATION

RATING SYMBOLS LEGEND



POSITIVE PRESSURE - CERTIFIED by UL to ANSI/UL10C Complies with IBC, NFPA 80 and NFPA 252 for application to hollow metal fire doors rated up to 3 hours, and wood fire doors rated up to 90 minutes (some ratings vary as noted).



CERTIFIED by UL to CAN/ULC-S104 and ANSI/UL10B Complies with NFPA 80 and NFPA 252 for application to hollow metal fire doors rated up to 3 hours, and wood fire doors rated up to 90 minutes (some ratings vary as noted).



NGP-EDGE® SEALING SYSTEM, CERTIFIED by UL to ANSI/UL10C Category 'G' Required for Category B wood fire doors to meet positive pressure requirements complying with IBC, and NFPA 252. See individual products for maximum door size and ratings.



SMOKE & DRAFT CONTROL GASKETING, CERTIFIED by UL to ANSI/UL10C and ANSI/UL 1784 Category 'H' Complies with IBC and NFPA 105 for use on 'S' labeled positive pressure hollow metal fire doors rated up to 3 hours, and wood fire doors rated up to 90 minutes (some ratings vary as noted).



ACOUSTICAL TESTED to ASTM E90 Standard Test Method for Laboratory Measurement of Airborne Sound Transmission Loss of Building Partitions and Elements, and ASTM E2235 Standard Test Method for Determination of Decay Rates for use in Sound Insulation Test Methods.



AIR INFILTRATION TESTED to ASTM E283, Standard Test Method for Determining Rate of Air Leakage Through Exterior Windows, Curtain Walls, and Doors.



ANSI/BHMA CERTIFIED Certified gasketing complies with American National Standard for Door Gasketing and Edge Seal Systems ANSI/BHMA A156.22, and is listed in the BHMA Certified Products Directory.



Online product listings: ul.com/database



BUY AMERICAN

REQUIREMENTS

Buy American Act

Over 99% of our products are produced in the United States as a domestic construction material, as defined in the Buy American Act (BAA) of March 1933 and amended by the Buy American Act of 1988 and FAR 52.225-9. A Buy American certificate may be obtained on our website ngp.com.

Build America, Buy America Act

Most of our products comply with Build America, Buy America Act requirements under Title IX of the Infrastructure Investment and Jobs Act (IIJA), Pub. L. 117-58, §§ 70901-70953. Contact us for a Certificate of Compliance for products being supplied on your project.

SADDLE THRESHOLDS

All Products In This Section



PART #	WIDTH
413*	4"
513*	5"
613*	6"
713*	7"
813*	8"
913	9"
1013	10"

PART #	WIDTH
424E	4"
425E	5"
426E	6"
427E	7"
428E	8"
429E	9"
430E	10"

NOTE: Flute Patterns Vary with Width of Threshold

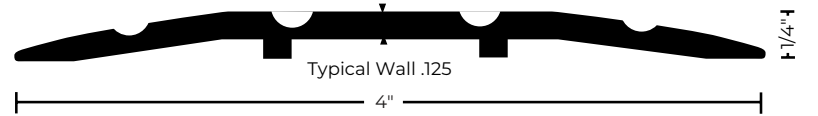

413 .53 lbs./ft.

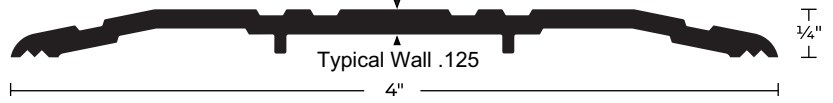

434 .54 lbs./ft.

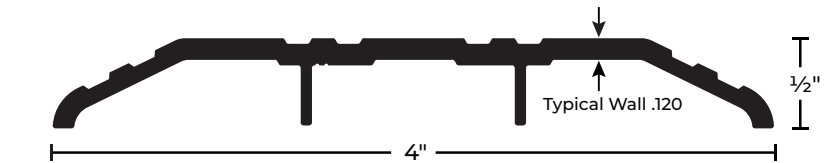

424E .65 lbs./ft.

MATERIALS & FINISHES

- No Suffix: Mill Aluminum
- DKB: Aluminum Dark Bronze/Black Anodized
- BR: Bronze (*Indicates if Available)

CROSS REFERENCE

NGP	413	513	613	713	813	913	1013	424E	425E	426E	427E	428E	429E	430E
PEMKO	270	271	272	276	2748	2749	2750	170	171	172	176	2548	2549	2550
ZERO	544	545	546	547	548	-	-	-	8655	-	6570	-	-	-
HAGER	403S	413S	417S	430S	428S	-	448S	404S	412S	415S	416S	426S	-	-
KN CROWDER	CT-64	CT-65	CT-66	CT-67	CT-68	CT-69	CT-610	CT-9	CT-10	CT-11	CT-12	CT-32	CT-909	CT-910

ADA COMPLIANT BUMPER SEAL THRESHOLDS

All Products In This Section



PART #	WIDTH
896	5"
950	5"

CROSS REFERENCE

NGP	896	950
PEMKO	2005	2001
ZERO	65	566
HAGER	520S	477S
KN CROWDER	CT-72	CT-70



896 .85 lbs./ft.

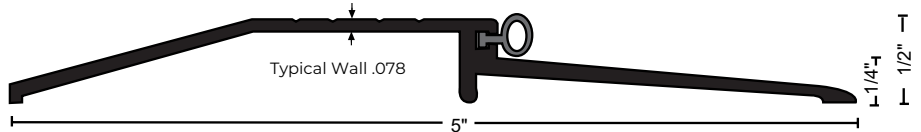

950 .50 lbs./ft.

MATERIALS & FINISHES

- No Suffix: Mill Aluminum
- DKB - Aluminum Dark Bronze/Black Anodized



OPTIONAL: SIA: SLIP-RESISTANT FINISH

For Use in Areas Where Conditions Can Be Hazardous and Safety Is a Priority

FASTENERS

- #10 x 1-1/2" FH Zinc-Plated Wood Screws Furnished. Dark Bronze Supplied With DKB



BUMPER SEAL

Seals Against the Door, Providing Weather Resistance

BUMPER SEAL OPTIONS

- V** Vinyl**
- N** Neoprene
- S** Silicone

**Vinyl ("V") Supplied Unless Other Material Specified

HEAVY-DUTY THRESHOLDS

All Products In This Section



- ▶ For Use Where Forklift or Vehicular Traffic Occurs
- ▶ Recommended for Delivery/Storage Doorways Where Heavier Loads Travel
- ▶ BHMA Certified to ANSI A156.21 Heavy Duty 10,000 lb. Load Test
- ▶ Optional SIA Slip-Resistant Finish Recommended in Moisture-Prone Areas

PART #	WIDTH
425HD	5"
513HD	5"
896HD	5"

MATERIALS & FINISHES

- No Suffix: Mill Aluminum
- DKB: Aluminum Dark Bronze/Black Anodized



BUMPER SEAL

Seals Against the Door, Providing Weather Resistance

BUMPER SEAL OPTIONS

- V** Vinyl**
- N** Neoprene
- S** Silicone

**Vinyl ("V") Supplied Unless Other Material Specified

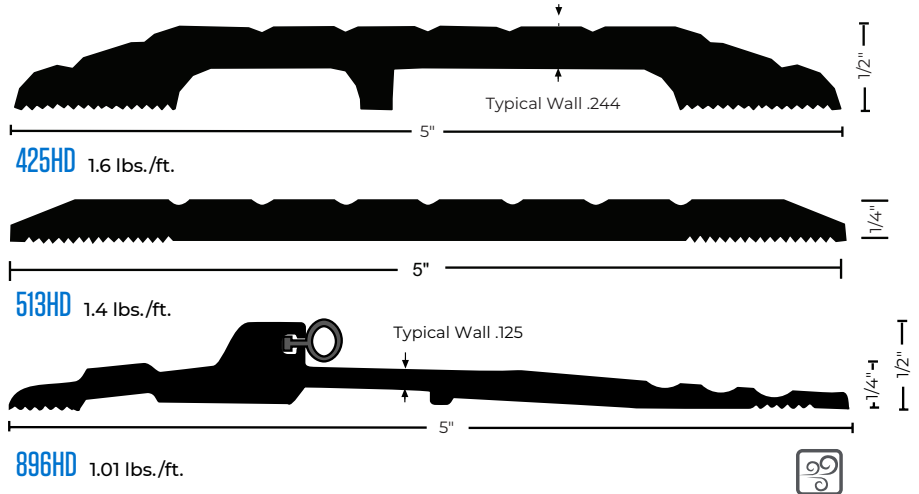

CROSS REFERENCE

NGP	425HD	513HD	896HD
PEMKO	1715	2715	2705-T
HAGER	427S	-	-

COVER PLATES

All Products In This Section



PART #	MAX WIDTH
818	48"
818SS	48"
814	48"
814SS	48"
838	48"

MATERIALS & FINISHES

- No Suffix: Mill Aluminum
- DKB: Aluminum Matte Black Powder Coat



OPTIONAL: SIA: SLIP-RESISTANT FINISH

For Use in Areas Where Conditions Can Be Hazardous and Safety Is a Priority

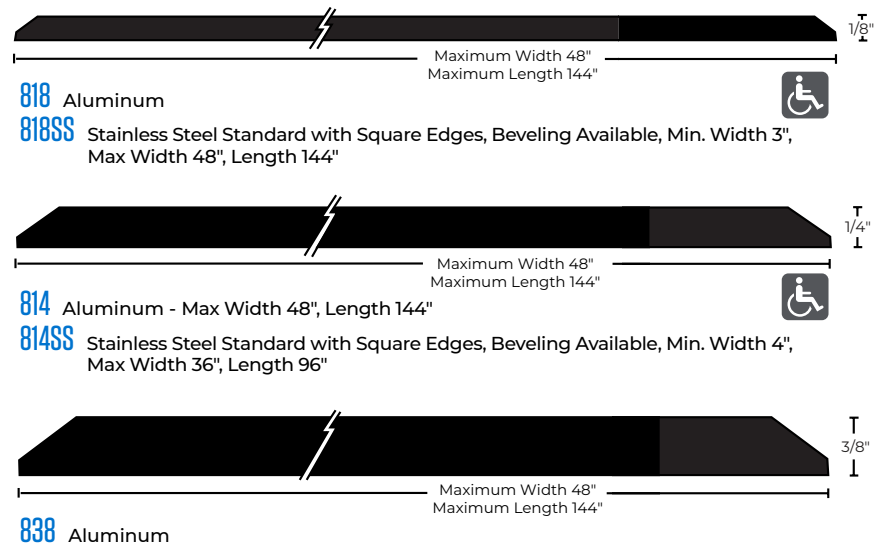

CROSS REFERENCE

NGP	818	818SS	814	814SS	838
PEMKO	18/1A	-	14/1A	-	-
ZERO	600CP	-	601CP	-	-
HAGER	676S	-	677S	-	-

HALF SADDLE THRESHOLDS

All Products In This Section



PART #	WIDTH
324	4"
325	5"

* When Installed with the Non-Beveled Edge Flush with Flooring or Where No Greater Than ¼" Vertical Rise Occurs.

CROSS REFERENCE

NGP	324	325
PEMKO	227	229
ZERO	1674	1675
HAGER	432S	431S

NOTE: Flute Patterns Vary with Width of Threshold

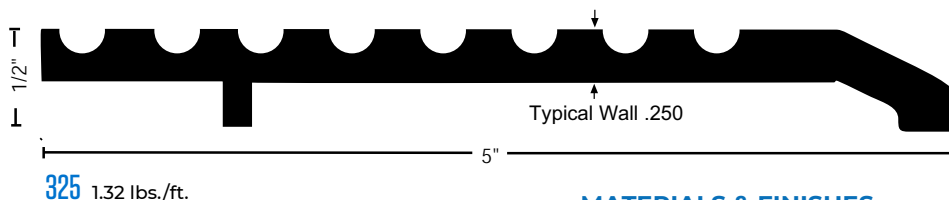
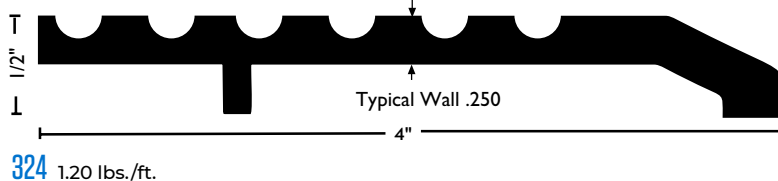

MATERIALS & FINISHES

- No Suffix: Mill Aluminum
- DKB: Aluminum Dark Bronze/Black Anodized

OFFSET SADDLE THRESHOLDS

All Products In This Section



PART #	WIDTH
653	5½"
659	7"

CROSS REFERENCE

NGP	653	659
PEMKO	158	2727
ZERO	211	103
HAGER	438S	--

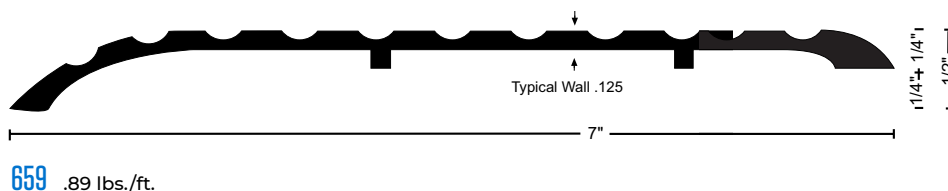
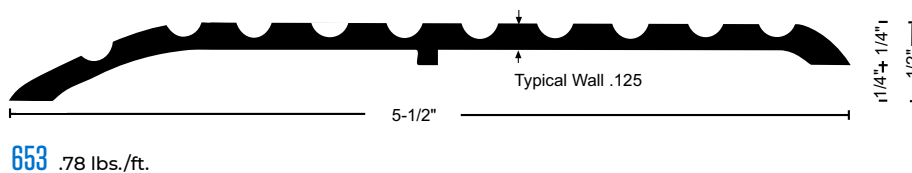

MATERIALS & FINISHES

- No Suffix: Mill Aluminum
- DKB: Aluminum Dark Bronze/Black Anodized



OPTIONAL: SIA: SLIP-RESISTANT FINISH

For Use in Areas Where Conditions Can Be Hazardous and Safety Is a Priority

THERMAL BREAK THRESHOLDS



PART #	WIDTH	BHMA CERTIFIED
8424	4"	BHMA CERTIFIED
8425	5"	BHMA CERTIFIED
8426	6"	BHMA CERTIFIED
8427	7"	
8428	8"	
8429	9"	
8430	10"	BHMA CERTIFIED

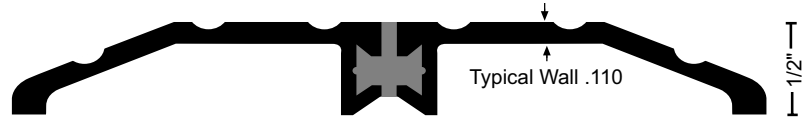

MATERIALS & FINISHES

- No Suffix: Mill Aluminum
- DKB: Aluminum Dark Bronze/Black Anodized



OPTIONAL:

SIA: SLIP-RESISTANT FINISH

For Use in Areas Where Conditions Can Be Hazardous and Safety Is a Priority

CROSS REFERENCE

NGP	8424	8425	8426	8427	8428	8429	8430
PEMKO	252 x 2_FG	252 x 3_FG	253 x 3_FG	253 x 4_FG	254 x 4_FG	254 x 5_FG	255 x 5_FG
ZERO	624	625	626	--	--	--	--
HAGER	420S	421S	422S	423S	424S	451S	452S
KN CROWDER	CT-44	CT-45	CT-46, CT-406	CT-407	CT-408	CT-409	CT-410

STAINLESS STEEL SADDLE



PART #	WIDTH
513SS	5"
512SS	5"

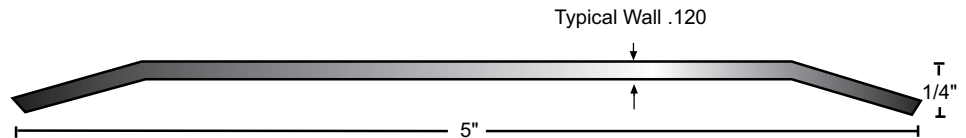

513SS 2.07 lbs./ft.

Available in 4" to 10" width.
1st digit = width (eg: 4" = 413SS)

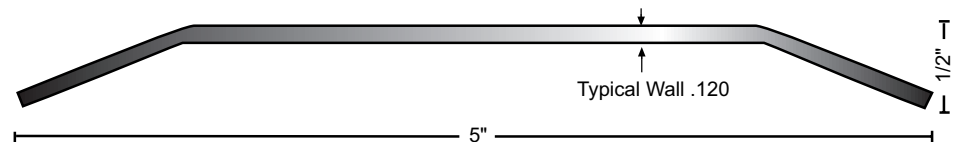

512SS 2.07 lbs./ft.

Available in 4" to 10" width.
1st digit = width (eg: 4" = 412SS)

CROSS REFERENCE

NGP	513SS	512SS
PEMKO	--	154SS
HAGER	--	412S-32D
KN CROWDER	--	CT-10SS

MATERIALS & FINISHES

- #304 Mill Finish Standard
- Available: Polished (US32)
Brushed (US32D)

SELF-ADHESIVE GASKETING

All Products In This Section



SILICONE BULB FIRE AND SMOKE SEAL

PART #	COLORS
5050B	BROWN
5050C	CHARCOAL
5050W	WHITE
5050CL*	CLEAR

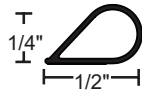

5050



Available in 17', 20', 21', 25' and 300* Rolls
*Clear Not Available in 300' Rolls

SILICONE BATWING SMOKE SEAL

PART #	COLORS
5020C	CHARCOAL
5020CL	CLEAR

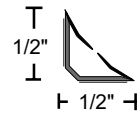

5020



Available in 3', 4', 7', 8' and 9' Lengths

SILICONE DOUBLE SHARK FIN SMOKE SEAL

PART #	COLORS
5070B	BROWN
5070CL	CLEAR

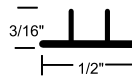

5070



Available in 4', 7', 8' and 9' Lengths
Smoke Rated for Perimeter and/or Meeting Edge (Astragal) Applications.

SILICONE TRIPLE FIN SMOKE SEAL

PART #	COLORS
5075C	CHARCOAL
5075CL	CLEAR
5075W	WHITE*

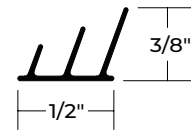

5075

Available in 17', 20', 21**, 25' and 300* Rolls
*White Only Available in 17' Rolls

CROSS REFERENCE

NGP	5050	5020	5070	5075
PEMKO	S88	S442	S772	S773
ZERO	188S	8144	8217S-BK	8150S-BK
HAGER	726	721	739	738S
KN CROWDER	W-22	-	-	W-63



EDGE SEALING SYSTEM:

Category "C" for 20 Minute Rated Category B Wood Doors Perimeter Application Up To:
Single Swing 4'0 X 8'0
Pairs 8'0 X 8'0
Use 9800 at the Meeting Edge of Pairs



SMOKE AND DRAFT CONTROL - CATEGORY "H":

Up to 3 Hours Hollow Metal Fire Doors
Up to 90 Minutes Wood Fire Doors
Meets Requirements of RoHS Directive
Use 5070 at the Meeting Edge of Pairs

CONCEALED FASTENER SEALS

- ▶ Snap-On Cover Conceals Screw Heads for Clean Appearance
- ▶ #6 X 3/4" Stainless Steel Sheet Metal Screws Furnished
- ▶ Screw Holes Slotted for Adjustment

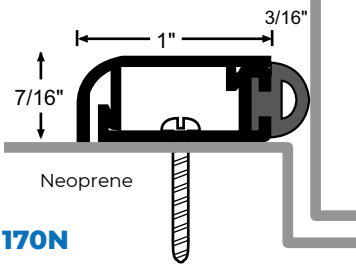

170N

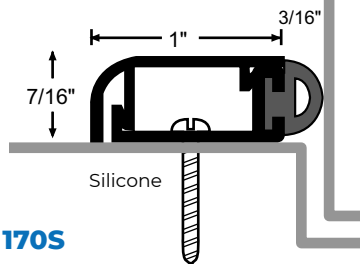

170S



170NA

Anodized Aluminum
Neoprene Perimeter
Seal with Concealed
Fastener

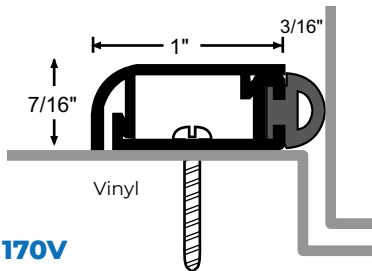

170V

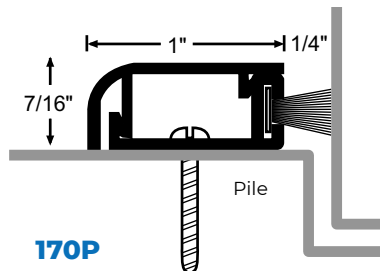

170P

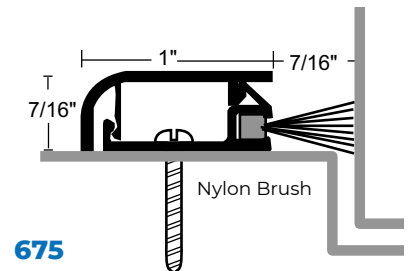

675

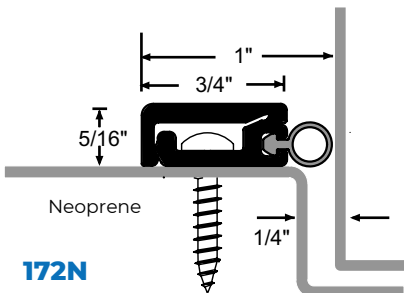

172N

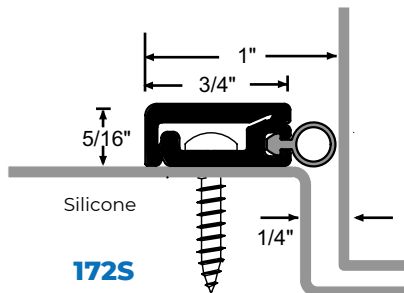

172S

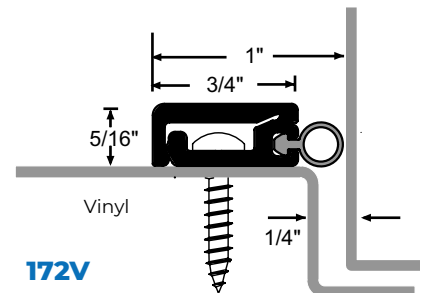

172V

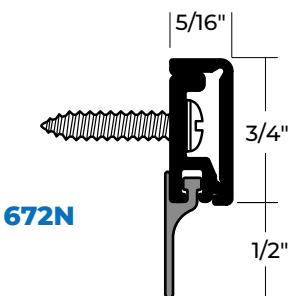

672N

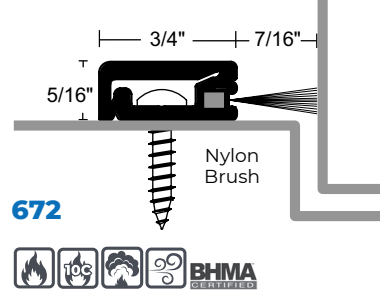

672



MATERIALS & FINISHES

- A: Clear Anodized Aluminum
- DKB: Aluminum Dark Bronze/Black Anodized

CROSS REFERENCE

NGP	170N	170S	170V	170P	675	172N	172S	172V	672N	672
PEMKO	29310	--	--	--	29324	--	--	--	29324_NB	--
ZERO	--	--	--	--	--	475, 8878	--	--	8142, 8879	8879
HAGER	885SN	885SS	885SV	885SW	882S	--	--	--	884SV	--
KN CROWDER	W-32N	W-32S	--	W-32P	--	--	--	--	--	--

GASKETING

All Products In This Section



PERIMETER SEALS

110N

Aluminum Neoprene Sponge Seal

- Neoprene is Black

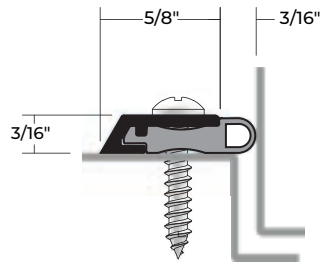

137N

Aluminum Neoprene Sponge Seal

- Neoprene

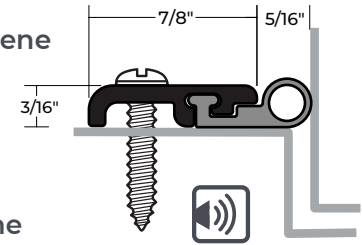

110S

Aluminum Silicone Sponge Seal

- Silicone

137S

Aluminum Silicone Sponge Seal

- Silicone

155S

Aluminum Silicone Bulb Perimeter Seal

- Dense Silicone

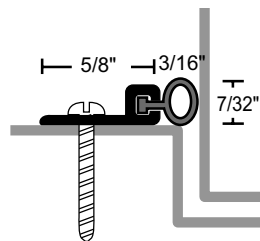

160V

Aluminum Vinyl Perimeter Seal

- Vinyl

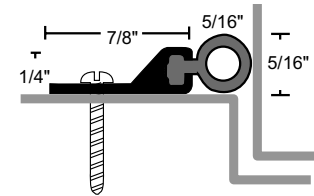

155V

Aluminum Vinyl Perimeter Seal

- Vinyl

160S

Aluminum Silicone Bulb Perimeter Seal

- Silicone

700N

Compatible with Parallel Arm Closers

- Neoprene

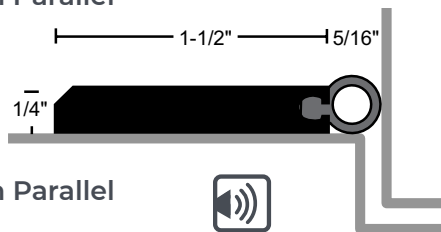

A605

Aluminum Nylon Brush Seal

- Nylon Brush

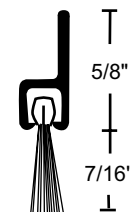

700S

Compatible with Parallel Arm Closers

- Silicone

A626

Aluminum Nylon Brush Seal

- Nylon Brush

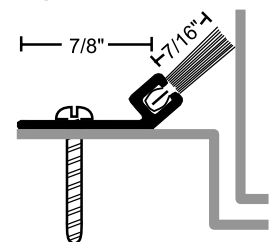

MATERIALS & FINISHES

- No Suffix: Mill Aluminum
- A: Clear Anodized Aluminum
- DKB: Aluminum Dark Bronze/Black Anodized

CROSS REFERENCE

NGP	110	137N	137S	155	160V	160S	700N	700S	A605	A626
PEMKO	332	319_E	--	--	303_V	303_S		2891-S	18041	45041
ZERO	--	326, 328	--	--	--	--	429	--	8193, 8304	--
HAGER	873S	862S	--		891SV	--	--	--	893S	803S
KN CROWDER	--	W-50S	W-50S	W-2	W-1	W-16	--	--	W-25S	W-23



GASKETING

ASTRAGALS

158N Aluminum Overlapping Astragal with Neoprene Seal

- Neoprene

158V Aluminum Overlapping Astragal with Vinyl Seal

- Vinyl

158S Aluminum Overlapping Astragal with Silicone Seal

- Silicone

158P Aluminum Overlapping Astragal with Polypropylene Pile Seal

- Polypropylene Pile

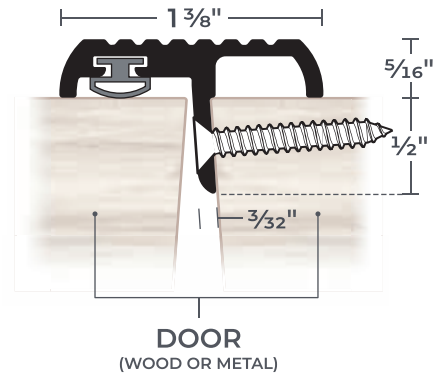

MATERIALS & FINISHES

- A: Clear Anodized Aluminum
- DKB: Aluminum Dark Bronze/Black Anodized

CROSS REFERENCE

NGP	158	115
PEMKO	355	329_N
ZERO	41, 383	8194
HAGER	837S	872S
KN CROWDER	W-9	W-5

115N Fire-Rated Aluminum Astragal with EPDM Seal

METAL	EPDM
A - Anodized Aluminum	Black
DKB - Aluminum Dark Bronze/Black Anodized	Black
No Suffix - Mill Aluminum	Black

*Specify Black Brush if Desired

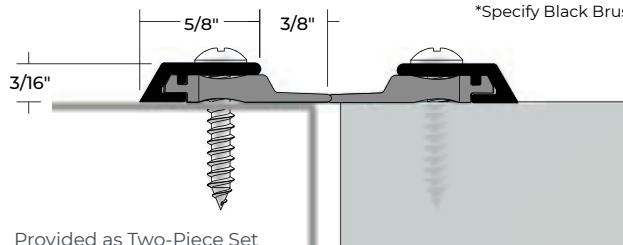

Provided as Two-Piece Set

All Products In This Section



ADJUSTABLE PERIMETER SEALS

103N Aluminum Adjustable Neoprene Perimeter Seal

- Neoprene

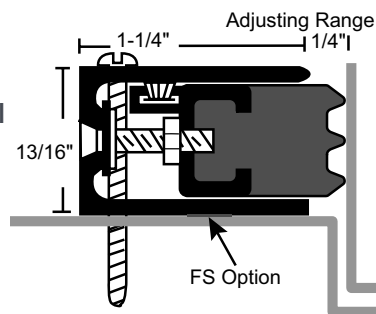

MATERIALS & FINISHES

- A: Clear Anodized Aluminum
- DKB: Aluminum Dark Bronze/Black Anodized

OPTIONS:

- Foam back seal - suffix 'FS'
- FATT - Fast Attach Tape

107N Aluminum Adjustable Neoprene Perimeter Seal

- Neoprene

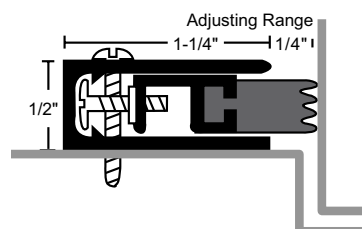

CROSS REFERENCE

NGP	103	107
PEMKO	350_S	379
ZERO	170	--
HAGER	865S	864S
KN CROWDER	--	W-42

107S Aluminum Adjustable Silicone Perimeter Seal

- Silicone

GASKETING

All Products In This Section



AUTOMATIC DOOR BOTTOMS

220N

Aluminum Surface,
Automatic Door Bottom
with Neoprene Seal

- Neoprene is Black

220S



Aluminum Surface,
Automatic Door Bottom
with Silicone Seal

- Silicone is Black

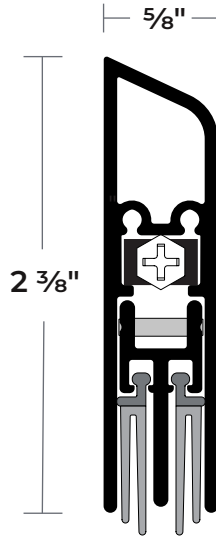

420N



Aluminum Heavy-Duty
Surface, Automatic
Door Bottom with
Neoprene Seal

- Neoprene is Black

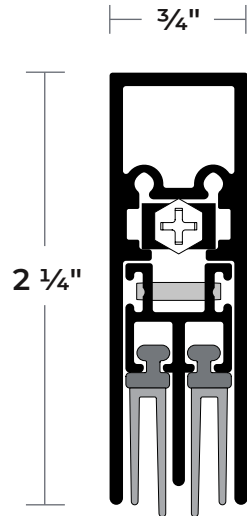

220WH

Aluminum Surface,
Automatic Door Bottom
with Nylon Brush Seal

- Aluminum Finish - *Gray Brush*
Aluminum Dark Bronze/Black
Anodized Finish - *Black Brush*

*Nylon Brush Recommended for
Carpet Applications Where No
Threshold is Provided.*

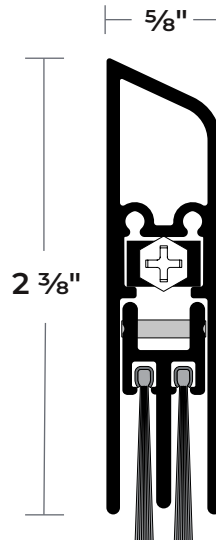

423NA



Mill Aluminum
Heavy-Duty Mortise
Automatic Door
Bottom

- Neoprene is Black

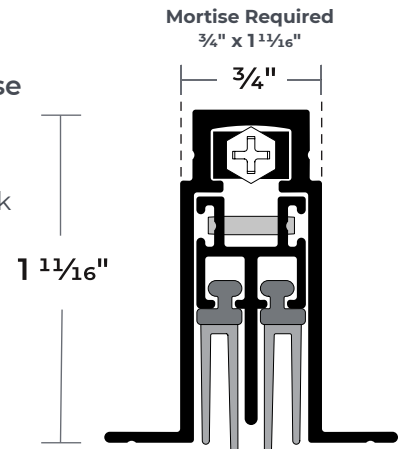

320NA

Clear Anodized Aluminum
Automatic Door Bottom
for Hollow Metal Doors

- Neoprene is Black

320SA

Clear Anodized Aluminum
Automatic Door Bottom
for Hollow Metal Doors

- Silicone is Black

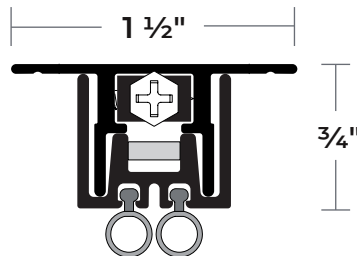

320VA

Clear Anodized Aluminum
Automatic Door Bottom for
Hollow Metal Doors

- Vinyl is Black

MATERIALS & FINISHES

- A: Clear Anodized Aluminum
- DKB: Aluminum Dark Bronze/
Black Anodized

CROSS REFERENCE

NGP	220	420N	423N	320
PEMKO	--	430	434	420
ZERO	--	361	360	355
HAGER	321	747S	743S	
KN CROWDER	--	CT-52	CT-53	742SN, 742SV

GASKETING

All Products In This Section



NYLON BRUSH SEALS WITH EPDM RUBBER INSERT

- EPDM Rubber Insert Protects Against Water Penetration and Provides an Effective Bottom Seal for Exterior Doors
- Excellent Abrasion Resistance, Flexibility and Memory
- Moisture-Resistant
- Retains Insecticides Well
- Temperature Range - 60°F to 300°F
- #6 x 3/4" Stainless Steel SMS Furnished
- Screw Holes Slotted for Adjustment

PRODUCT#	FINISH
SUFFIX	
A	Clear Anodized with Black Brush
DKB	Aluminum Dark Bronze/ Black Anodized with Black Brush

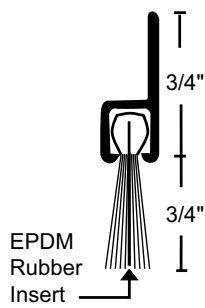

C697

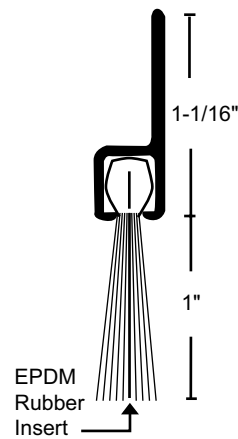

D698

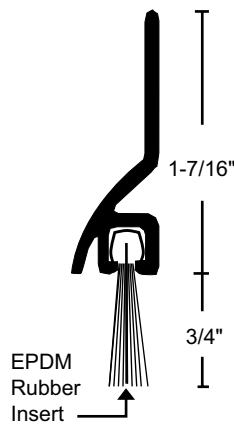

C699

GASKETING

All Products In This Section



DOOR SWEEPS

C627 BHMA CERTIFIED Nylon Brush Sweep

- Aluminum Finish - *Gray Brush*
- Aluminum Dark Bronze/Black Anodized Finish - *Black Brush*

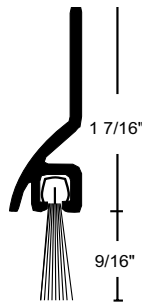

97V Vinyl Sweep

- Vinyl is Black

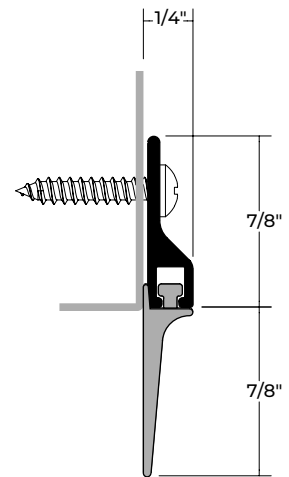

675 BHMA CERTIFIED Concealed Fastener Nylon Brush Perimeter Seal or Sweep

- Aluminum Finish - *Gray Brush*
- Aluminum Dark Bronze/Black Anodized Finish - *Black Brush*

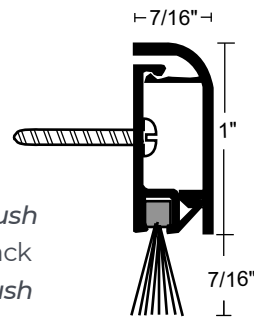

200N BHMA CERTIFIED Aluminum Neoprene Door Sweep

200S BHMA CERTIFIED Aluminum Silicone Door Sweep

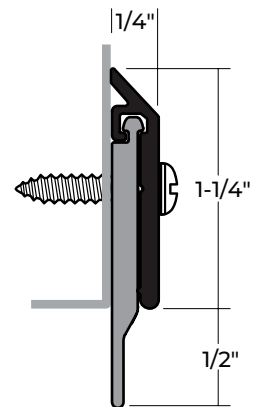

101V Aluminum Vinyl Door Sweep

- Vinyl is Black

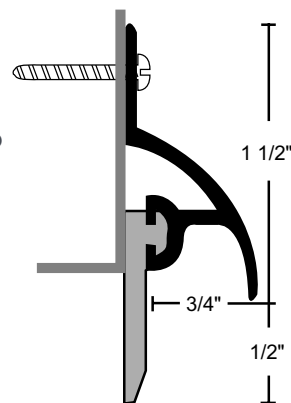

CROSS REFERENCE

NGP	C627	97V	675	200	101V
PEMKO	345_NB	307	29324	315_N	345_V
ZERO	8198	8191	-	50M/39	8197
HAGER	770SB	756S	882S	750S	770SV
KN CROWDER	W-35-1	W-4	-	W-13S, W-38S	-

MATERIALS & FINISHES

- No Suffix: Mill Aluminum
- A: Clear Anodized Aluminum
- DKB: Aluminum Dark Bronze/Black Anodized



DOOR SHOES

12V

Aluminum Smooth Vinyl Door Shoe

- ▶ Vinyl is Black

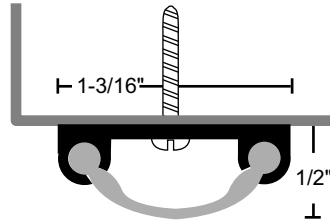

319EV

Aluminum Finned Vinyl Door Shoe

- ▶ Vinyl is Black

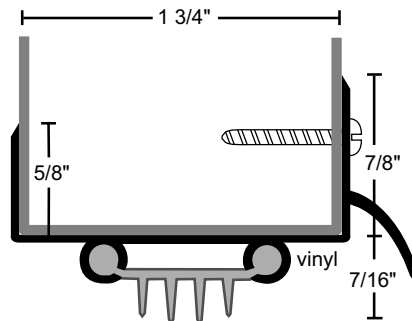

36ET6

Aluminum Thermoplastic Door Shoe

- ▶ Thermoplastic is Dark Brown

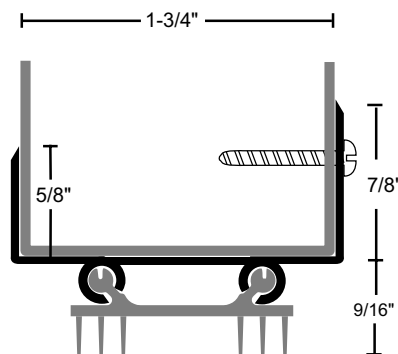

CROSS REFERENCE

NGP	12V	319EV	36ET6
PEMKO	208_V	216	-
HAGER	-	778SV	-
KN CROWDER	-	CT-745	-

MATERIALS & FINISHES

- No Suffix: Mill Aluminum
- DKB: Aluminum Dark Bronze/Black Anodized



VINYL THRESHOLDS, SMOKE SEAL

401

Hospitality Vinyl Carpet/Tile Divider Threshold

- Vinyl is Black

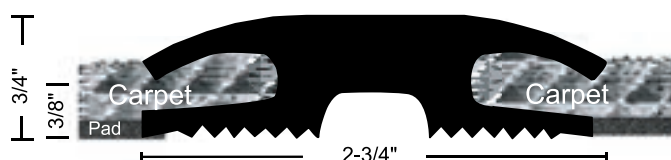

* When Installed as Illustrated Between Carpet and/or Tile

400

Hospitality Vinyl Carpet/Tile Divider Threshold

- May be Field Trimmed for Narrower Widths
Max Length = 73"
- Vinyl is Black

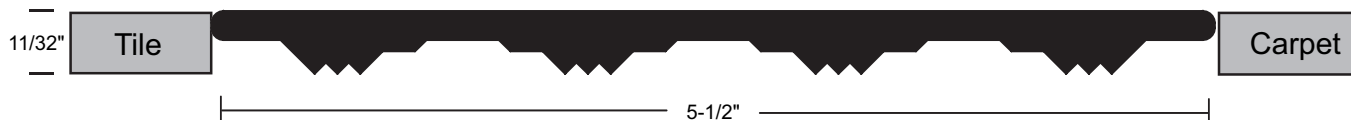

* When Installed as Illustrated Between Carpet and/or Tile

5075

Silicone Triple Fin Smoke Seal

PART #	COLORS
5075C	CHARCOAL
5075CL	CLEAR
5075W	WHITE*

Available in 17', 20', 21'**, 25" and 300** Rolls

* White Only Available in 17' Rolls

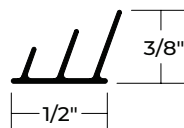

CROSS REFERENCE

NGP	401	400	5075
PEMKO	EV232BL	--	S773
ZERO	1685	--	8150S-BK
HAGER	900S	905S	738S
KN CROWDER	--	--	W-63

HOSPITALITY

DOOR BOTTOMS, DOOR SHOES, DOOR GUARDS

335NA

Mortise Automatic Door Bottom with Neoprene Seal

- ▶ Minimum Length 11 1/2", Maximum Length 60"
- ▶ Fits Wood Fire Door Mortise Restrictions
- ▶ Neoprene is Black

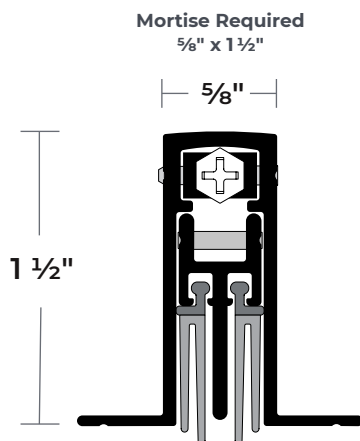

36ET

Thermoplastic Door Shoe

- ▶ Thermoplastic is Dark Brown

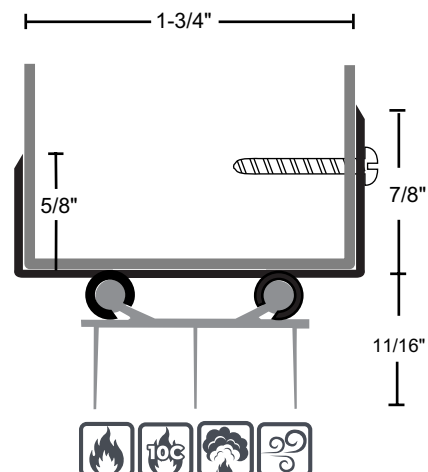

SDG

Security Door Guard

SKU	COLORS
SDG-3	POLISHED BRASS US3
SDG-4	SATIN BRASS US4
SDG-10B	DARK BRONZE US10B
SDG-26	POLISHED CHROME US26
SDG-26D	SATIN CHROME US26D
SDG-DS*	STICKER FOR RETROFIT
SDG-WS*	STICKER FOR RETROFIT

*Covers Holes Left in Door and Frame from Removal of Swing-Bar Type Door Guards

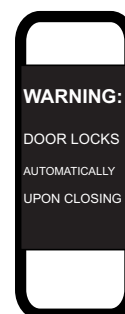
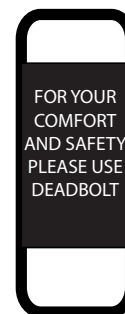
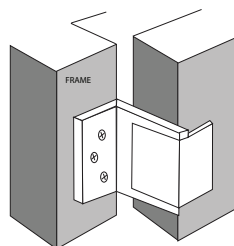
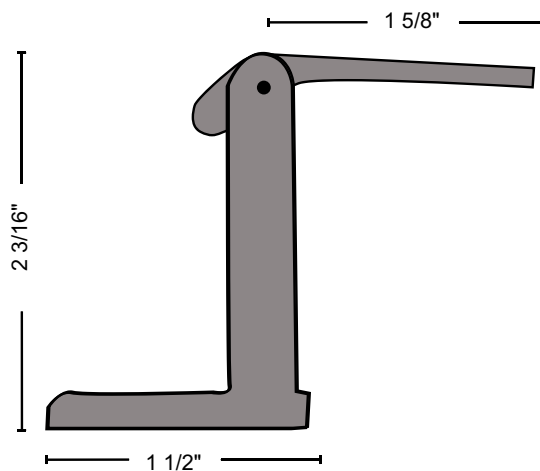

SDG-DS SDG-WS

CROSS REFERENCE

NGP	335N	36ET	SDG
PEMKO	411	--	PDL
ZERO	320	--	--
KN CROWDER	CT-51	--	--

FINGER GUARD

Prevent Injury to Fingers Accidentally Placed in the Hinge Area of a Door

- ▶ Ideal for Senior & Childcare Facilities
- ▶ Anodized Aluminum Housing
- ▶ Durable “Endless Cycle” Spring Mechanism
- ▶ Mounts on Push Side of Door

2248



SKU	MATERIAL
2248	Aluminum Clear Anodized W/ White Polyethylene
2248DKB	Dark Bronze/Black Anodized W/ Black Polyethylene

Rated Up to 3 Hours Metal Doors, 1 Hour Wood Doors

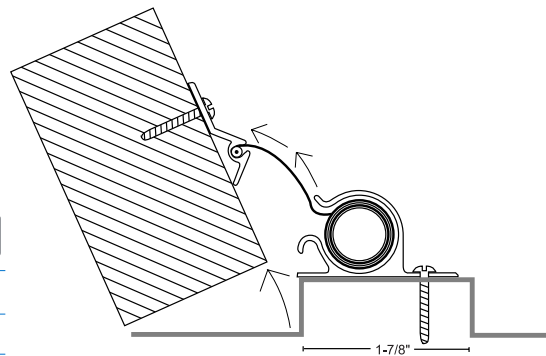

Details Not to Scale

HINGE SIDE FINGER GUARD

- ▶ Available in Brown, Charcoal and White
- ▶ 83" Length
- ▶ Can Be Cut in the Field
- ▶ Mounts on Pull Side of Door
- ▶ #6 X 1/2" Tek Self-Drilling Screws

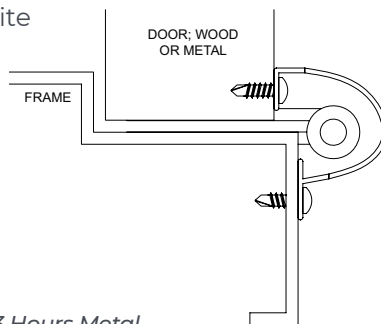

2252



SKU	COLOR
2252C	CHARCOAL
2252W	WHITE

Rated Up to 3 Hours Metal Doors, 1 1/2 Hours Wood Doors

CROSS REFERENCE

NGP	2248	2252
ZERO	--	951, 972, 974

FLOOD SHIELD

- ▶ 1/4" Marine Grade Aluminum Shield with Handle Cutouts
- ▶ Closed Cell Neoprene Rubber Gaskets Installed on Bottom and Sides of Shield
- ▶ Anodized Aluminum Mounting Channels
- ▶ Universal Channels can Install Inside or Outside Mount
- ▶ Stainless Steel Springs Provide Seal Compression

SKU	HEIGHT	
FS10	12" High	With 10" of Flood Protection
FS22	24" High	With 22" of Flood Protection
FS34	36" High	With 34" of Flood Protection

- ▶ Complies with Guidelines of the Federal Emergency Management Agency (FEMA) and Federal Insurance and Mitigation Administration (FIMA) for Use on Doors in Flood Prone Areas
- ▶ Lengths Up To 96" Available
- ▶ A Center Support Post is Recommended for Installations Over 50"
- ▶ Orders for this Product are Non-Changeable and Non-Cancellable



MOUNTING CHANNEL

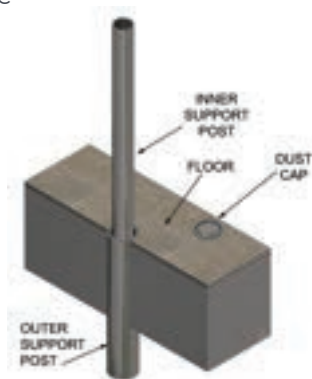
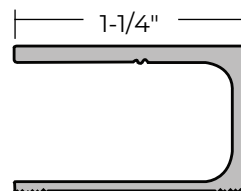

FSSP Optional Center Support & Cap

CROSS REFERENCE

NGP	FS10	FS22	FS34	FSSP
ZERO	2070A-10	2070A-24	2070A-36	--

LITE KITS & LOUVERS

L-FRA100

Low Profile Lite Kit

- For 1 3/4" Thick Doors and 3/16", 1/4", or 5/16" Glass
- 18 Ga. Cold Rolled Steel
- Mitered and Welded Corners
- Gray Primer (GPZ) Powder Coat Finish Standard

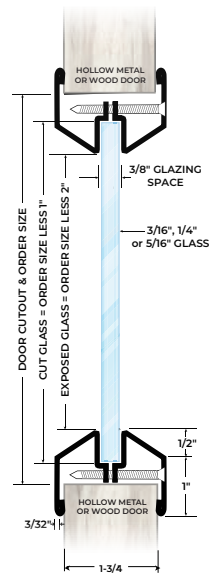

L-CVFM-SS

Stainless Steel Lite Kit

- For 1 3/4" Thick Doors and 3/16", 1/4", or 5/16" Glass
- 18 Ga. Type 304 Stainless Steel
- Mitered and Welded Corners
- #4 Satin Finish

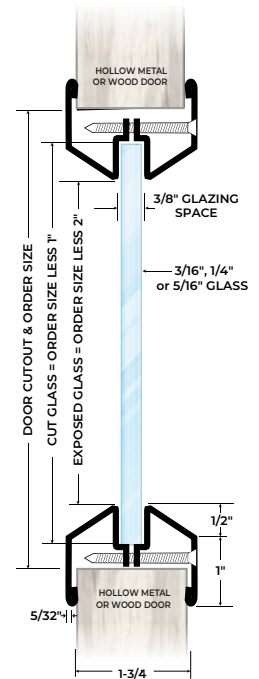

L-700-RX, AFDL

Self-Attaching, No Vision Door Louver

- For 1 3/4" Thick Doors
- 18 Ga. Cold Rolled Steel
- Mitered and Welded Corners
- Inverted "V" Design
- Gray Primer (GPZ) Powder Coat Finish Standard

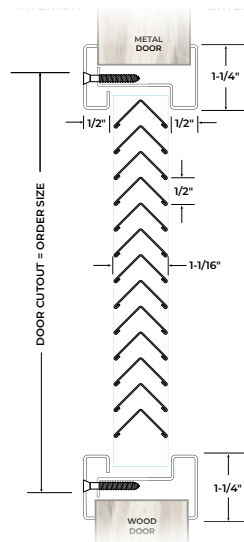

L-700-A

Steel No Vision Door and Partition Louver

- For 1 3/8", 1 3/4" up to 2 1/4" Thick Doors
- 20 Ga. Cold Rolled Steel
- Mitered and Welded Corners
- Inverted "V" Design
- Gray Primer (GPZ) Powder Coat Finish Standard

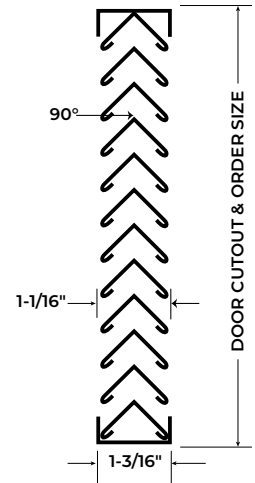

CROSS REFERENCE

NGP	L-FRA100	L-CVFM-SS	L-700-RX	L-700-A
AIR LOUVERS	VSL	VSL-S	800A1, 600A1	800 Series
ROCKWOOD	LT-B1	LT-B1 Stainless Steel	LV-1Y	--

LITE KITS & LOUVERS



Anemostat

DOOR PRODUCTS

LO-PRO

Low Profile Lite Kit

- For 1-3/4" Thick Doors and 3/16", 1/4", or 5/16" Glass
- 20 Ga. Cold Rolled Steel
- Mitered and Welded Corners
- Gray Primer (GPZ) Powder Coat Finish Standard

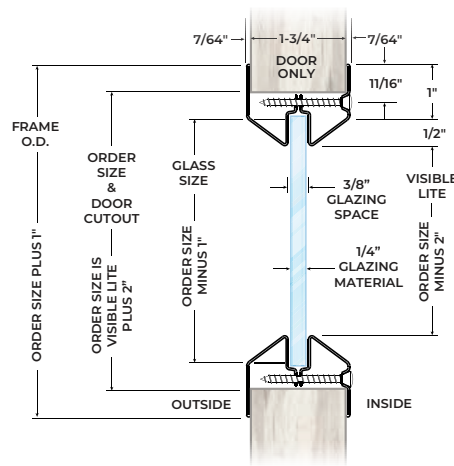

Anemostat

DOOR PRODUCTS

LO-PRO-IS

Low Profile Lite Kit

- For Variable Door and/or Glass Thickness
- 20 Ga. Cold Rolled Steel
- Mitered and Welded Corners
- Gray Primer (GPZ) Powder Coat Finish Standard

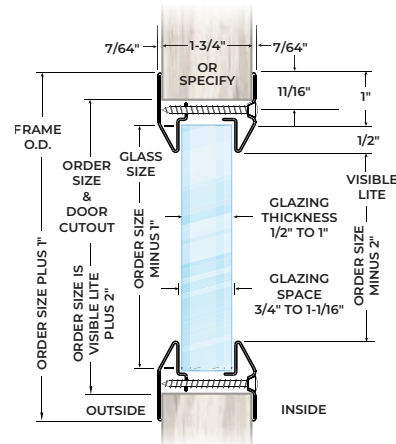

Anemostat

DOOR PRODUCTS

FDLS

Inverted Split Y No Vision Door Louver

- For 1-1/8" and Over Thick Doors
- 18 Ga. Cold Rolled Steel
- Mitered and Welded Corners
- Available in Uneven and Fractional Sizes
- Fractional Sizes Fabricated with 1-1/2" Frame
- Gray Primer (GPZ) Powder Coat Finish Standard

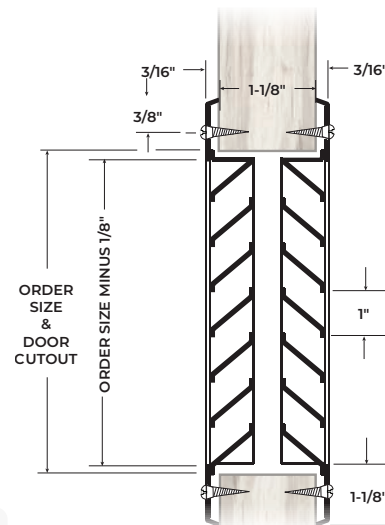

CROSS REFERENCE

NGP	LO-PRO	LO-PRO-IS	FDLS
AIR LOUVERS	VSL	VSIG	700A
ROCKWOOD	LT-B1	LT-B2, LT-B3, LT-B4	-

GLASS

PROTECT3™

Fire Protective Safety Wired Glass

- ¼" Thick
- Safety Filmed Wired Glass
- Fire Protective Rated
- Impact Safety-Rated
- STC 28

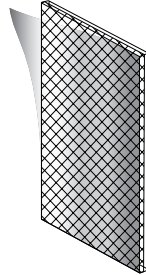

PYRAN® PLATINUM F

Fire-Protective Safety Glass Ceramic

- ⅜" Thick
- Safety Filmed Glass Ceramic
- Fire Protective Rated
- Impact Safety-Rated
- Clear & Wireless Glass
- STC 31



20T

20-Minute Fire-Protective Glass

- ¼" Thick
- Clear & Wireless, Tempered Glass
- Superior Optical Clarity
- Fire Protective Rated
- Impact Safety-Rated
- STC 28

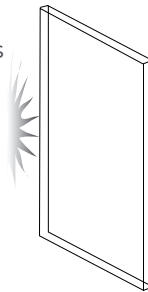

LAMINATED GLASS

Impact Safety-Rated Laminated Architectural Glass

- ¼" Thick
- Comprised of Two Pieces of Glass and a .030" PVB Interlayer
- Manufactured in USA
- NON-Fire-Rated
- STC 35

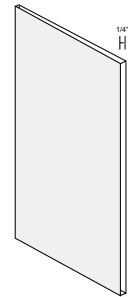

TEMPERED GLASS

- ¼" Thick
- Heat Treated Glass
- Impact Safety-Rated
- Clear & Wireless Glass
- STC 31

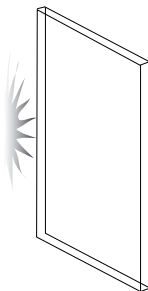

INSULATED TEMPERED GLASS

- 1" Thick
- Comprised of Two Pieces ¼" Thick Clear Tempered Glass With ½" Air Space Between and Butyl Seal
- Impact Safety-Rated
- Clear & Wireless Glass
- STC 35

CROSS REFERENCE

PROTECT3	PYRAN® PLATINUM F	20T
WireLiteNT, Wireshield	FireLite® NT	Fireglass 20

CONTINUOUS HINGE

All Products In This Section



ALUMINUM GEARED

CONCEALED

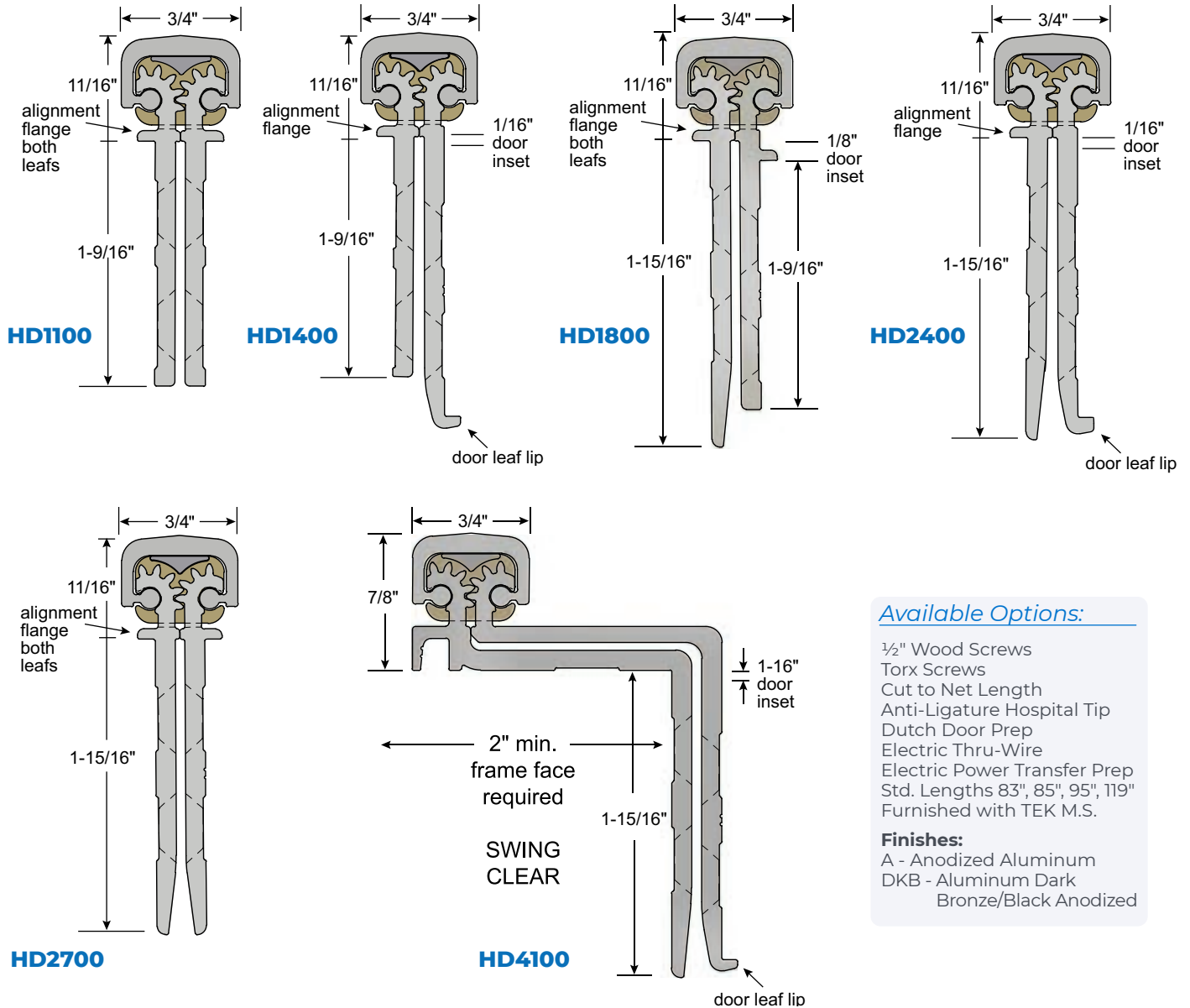

- Available Options:**
- 1/2" Wood Screws
 - Torx Screws
 - Cut to Net Length
 - Anti-Ligature Hospital Tip
 - Dutch Door Prep
 - Electric Thru-Wire
 - Electric Power Transfer Prep
 - Std. Lengths 83", 85", 95", 119"
 - Furnished with TEK M.S.
- Finishes:**
- A - Anodized Aluminum
 - DKB - Aluminum Dark Bronze/Black Anodized

CROSS REFERENCE						
NGP	HD1100	HD1400	HD1800	HD2400	HD2700	HD4100
SELECT	SL11 HD	SL14 HD	SL18 HD	SL24 HD	-	SL41HD
ROTON	780-112LL	780-124HD	780-111HD	780-224HD	780-226HD	780-041HD
PEMKO	FMSLF-HD1	SPFM-HD1	FMSLI-HD1	FM-HD1	-	OSFM-HD1
STANLEY	661HD	-	-	662HD	-	-
ABH	A110HD	A140HD	A111HD	A240HD	A270HD	A410HD
PBB	CG31	-	CG311	CG31L	CG31P	CG31CL
IVES	112HD	114XY	-	224HD	-	-

CONTINUOUS HINGE

All Products In This Section



ALUMINUM GEARED

HALF SURFACE

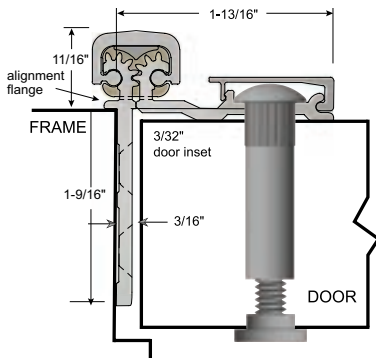

HD5300

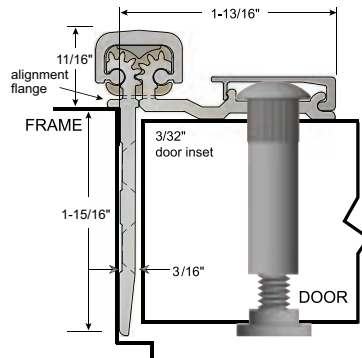

HD5400

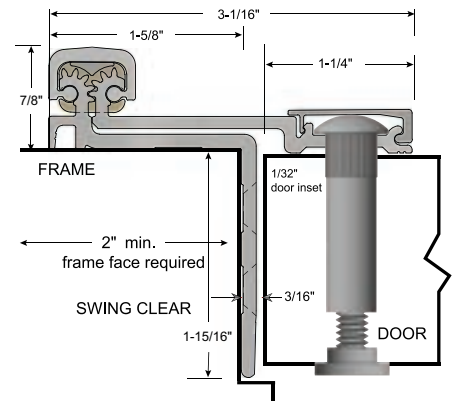

HD4200

FULL SURFACE

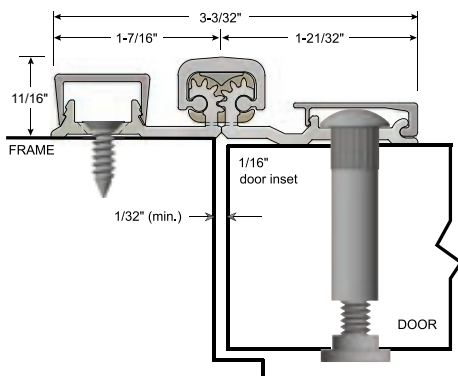

HD5700

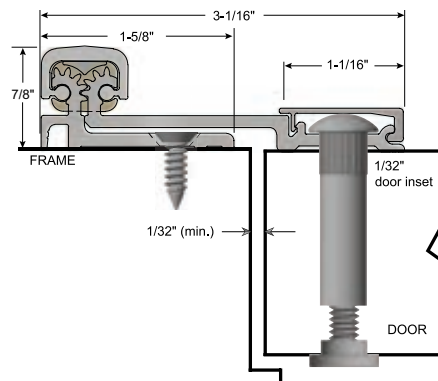

HD2100

Available Options:

- 1/2" Wood Screws
- Torx Screws
- Cut to Net Length
- Anti-Ligature Hospital Tip
- Dutch Door Prep
- Electric Thru-Wire
- Electric Power Transfer Prep
- Std. Lengths 83", 85", 95", 119"
- Furnished with TEK M.S.

Finishes:

- A - Anodized Aluminum
- DKB - Aluminum Dark
- Bronze/Black Anodized

CROSS REFERENCE

NGP	HD5300	HD5400	HD4200	HD5700	HD2100
SELECT	SL53 HD	SL54 HD	-	SL57 HD	SL21 HD
ROTON	780-053HD	780-54HD	780-211HD	780-157HD	780-210HD
PEMKO	-	HS-HD1	OSHS-HD1	FSCP-HD1	FS-HD1
STANLEY	-	663HD	-	664HD	665HD
ABH	A530HD	A540HD	A211HD	A570HD	A210HD
PBB	CG34N	CG34	-	CG33N	CG33C
IVES	053HD	054HD	-	157XY	210HD

CONTINUOUS HINGE

All Products In This Section



STAINLESS STEEL

CONCEALED

14 Gauge Type 304 Stainless Steel Pin and Barrel Design

FULL MORTISE (EDGE MOUNT)

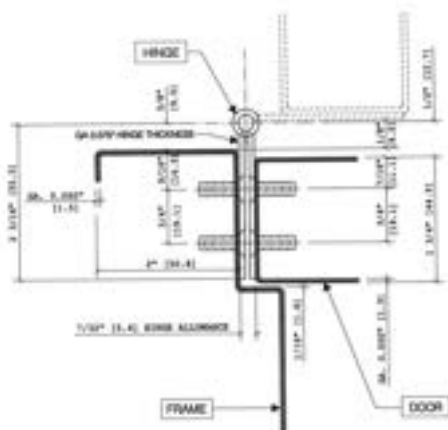

SS300

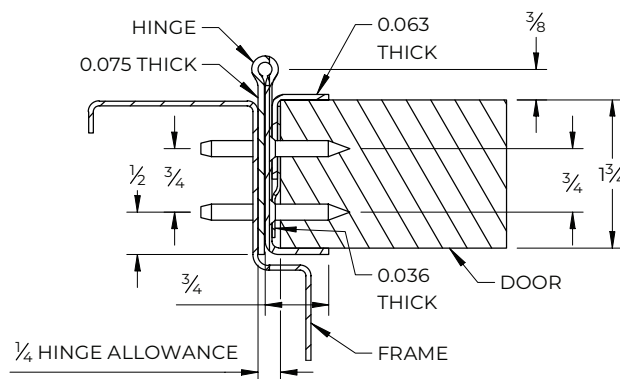

SS305

HALF WRAP EDGE GUARD (EDGE MOUNT)

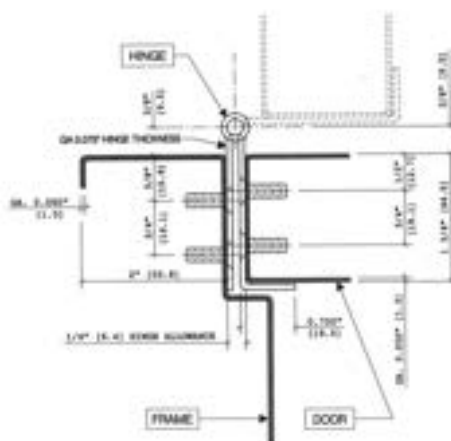

SS315

CROSS REFERENCE

NGP	SS300	SS305	SS315
MARKAR	FM300	HG305	HG315
SELECT	SL300	SL305	SL315
HAGAR	790-900	790-905	790-915
ABH	A500	A505	A515
IVES	700	705	715
STANLEY	651	652	653
PBB	CH51	CH51G	CH51L

Available Options:

- 1/2" Wood Screws
- Torx Screws
- Cut to Net Length
- Anti-Ligature Hospital Tip
- Dutch Door Prep
- Welded Tips
- Electric Thru-Wire
- Electric Power Transfer Prep
- Std. Lengths 83", 85", 95", 119"
- Furnished with TEK M.S.
- Wood Screws

Finishes:

- Brushed Stainless Steel
- US32D (630)

CONTINUOUS HINGE

All Products In This Section



STAINLESS STEEL

FULL SURFACE

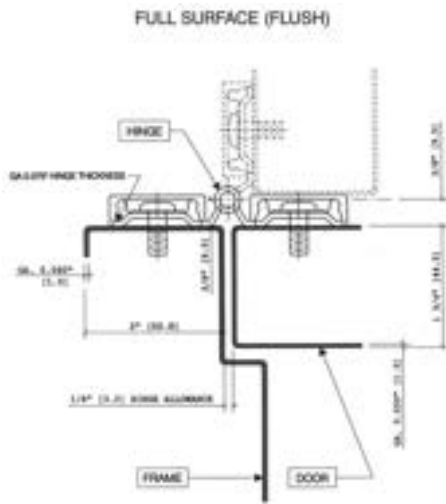

SS302

SWING CLEAR

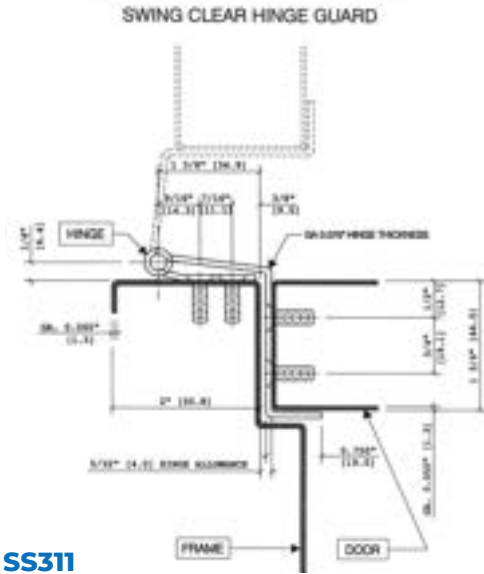

SS311

HALF MORTISE

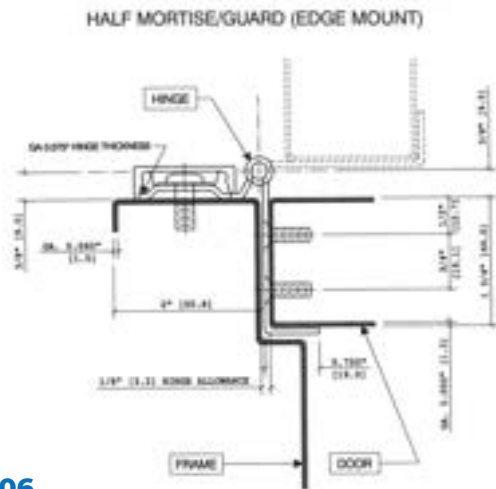

SS306

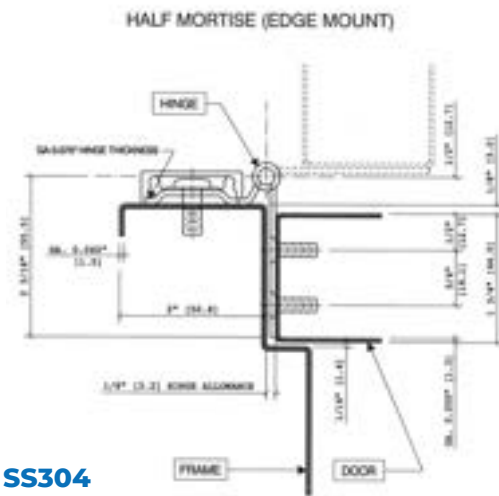

SS304

CROSS REFERENCE

NGP	SS302	SS311	SS306	SS304
MARKAR	FS302	HG311	HG306	HM304
SELECT	SL302	SL311	SL306	-
HAGAR	-	790-911	790-906	790-904
ABH	A502	A511	A506	A504
IVES	702	711	-	-
STANLEY	657	656	655	654
PBB	CH53	CH52CL	CH52L	CH52

Available Options:

- 1/2" Wood Screws
- Torx Screws
- Cut to Net Length
- Anti-Ligature Hospital Tip
- Dutch Door Prep
- Welded Tips
- Electric Thru-Wire
- Electric Power Transfer Prep
- Std. Lengths 83", 85", 95", 119"
- Furnished with TEK M.S.

Finishes:

- Brushed Stainless Steel
- US32D (630)

SLIDING DOOR HARDWARE

BY-PASS, BI-FOLD

SLAL-75-BP

Aluminum By-Pass Side Mount Track System

SKU	TRACK LENGTH
SLAL-75-BP-48	48"
SLAL-75-BP-60	60"
SLAL-75-BP-72	72"
SLAL-75-BP-96	96"



SLAL-75-BPF

Aluminum By-Pass Side Mount Track System with Fascia

SKU	TRACK LENGTH
SLAL-75-BPF-48	48"
SLAL-75-BPF-60	60"
SLAL-75-BPF-72	72"
SLAL-75-BPF-96	96"



SLAL-75-BF

Aluminum Bi-Fold Top Mount Track System

TWO-DOOR SYSTEMS

SKU	TRACK LENGTH
SLAL-75-BF2DR-36	36"
SLAL-75-BF2DR-48	48"

FOUR-DOOR SYSTEMS

SKU	TRACK LENGTH
SLAL-75-BF4DR-60	60"
SLAL-75-BF4DR-72	72"
SLAL-75-BF4DR-96	96"



CROSS REFERENCE

NGP	SLAL-75-BP	SLAL-75-BPF	SLAL-75-BF
HAGER	9514	9614	9570
PEMKO	-	-	HF2/100A
STANLEY	BPC60A-00	-	BFC50-00
LE JOHNSON	2200	2200F	100FS
KN CROWDER	C-600	-	CF-100

SLIDING DOOR HARDWARE

BY-PASS, SIDE WALL MOUNT

SLAL-250-BP

Aluminum By-Pass Top Mount Track System

TWO-DOOR SYSTEMS

SKU	TRACK LENGTH
SLAL-250-BP-2DR-48	48"
SLAL-250-BP-2DR-60	60"
SLAL-250-BP-2DR-72	72"
SLAL-250-BP-2DR-96	96"
SLAL-250-BP-2DR-144	144"

FOUR-DOOR SYSTEMS

SKU	TRACK LENGTH
SLAL-250-BP-4DR-48	48"
SLAL-250-BP-4DR-60	60"
SLAL-250-BP-4DR-72	72"
SLAL-250-BP-4DR-96	96"
SLAL-250-BP-4DR-144	144"

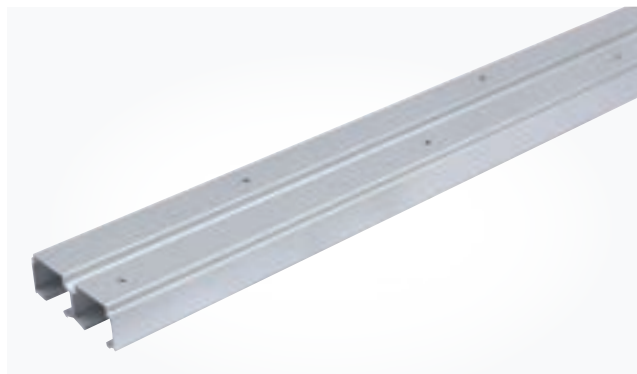

SLAL-250-SW

Aluminum Side Wall Mount Track System

SKU	TRACK LENGTH
SLAL-250-SW-48	48"
SLAL-250-SW-60	60"
SLAL-250-SW-72	72"
SLAL-250-SW-96	96"
SLAL-250-SW-144	144"

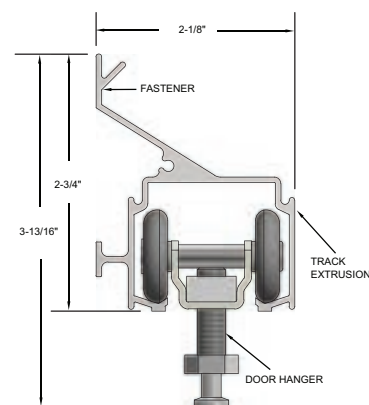
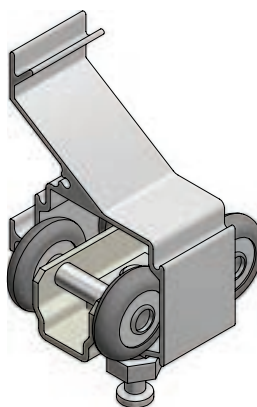

CROSS REFERENCE

NGP	SLAL-250-BP	SLAL-250-SW
HAGER	9611	9710
PEMKO	HBP200A	280C-SWKIT
STANLEY	BPC150N-00	--
LE JOHNSON	100SM	2610
KN CROWDER	C-500	C-412

SLIDING DOOR HARDWARE

POCKET DOOR/FRAME KIT

SLAL-250-PD

Aluminum Top Mount Track System **BHMA CERTIFIED**

SKU	TRACK LENGTH
SLAL-250-PD-48	48"
SLAL-250-PD-60	60"
SLAL-250-PD-72	72"
SLAL-250-PD-96	96"
SLAL-250-PD-144	144"

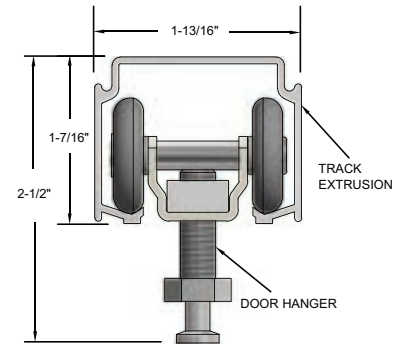
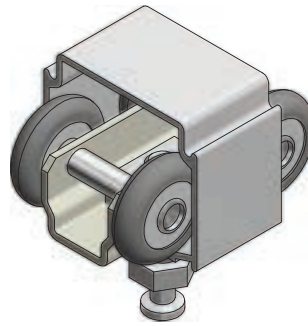

SLAL-250-PDKIT

Aluminum Top Mount Track System

SKU	APPLICATION	FOR UP TO:
SLAL-250-PDKIT	4" Wood or Metal Stud	3/0 x 7/0
SLAL-250-PDKIT-48"DR	4" Wood or Metal Stud	4/0 x 7/0
SLAL-250-PDKIT-6	6" Wood Stud (5 1/2" Header)	3/0 x 7/0
SLAL-250-PDKIT-6-48"	6" Wood Stud (5 1/2" Header)	4/0 x 7/0
SLAL-250-PDKIT-6M	6" Metal Stud (6" Header)	3/0 x 7/0
SLAL-250-PDKIT-6M-48"	6" Metal Stud (6" Header)	4/0 x 7/0

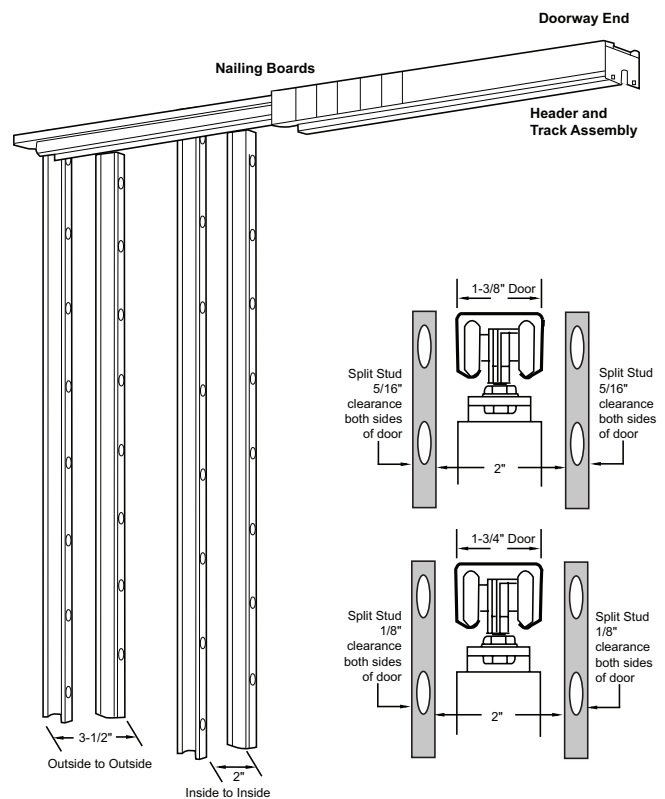

CROSS REFERENCE

NGP	SLAL-250-PD	SLAL-250-PDKIT
HAGER	9678	9630
PEMKO	H200A	PF28200A6080
STANLEY	PDC150N-00	PDC150N-00
LE JOHNSON	100PD	1500PF
KN CROWDER	C-411	TYPE B

SLIDING DOOR HARDWARE

STAINLESS STEEL

SLSS1

Sliding Door Hardware, Stainless Steel Top Mount Round Track System



STAINLESS STEEL TOP MOUNT ROUND TRACK SYSTEM (WITH SOFT CLOSE)

STAINLESS STEEL TOP MOUNT ROUND TRACK SYSTEM

SKU	TRACK LENGTH
SLSS1-6	78 ³ / ₄ "
SLSS1-8	98 ⁷ / ₁₆ "

SKU	TRACK LENGTH
SLSS1-6-SC*	78 ³ / ₄ "
SLSS1-8-SC*	98 ⁷ / ₁₆ "

SLSS2

Sliding Door Hardware, Stainless Steel Side Mount Round Track System



STAINLESS STEEL SIDE MOUNT ROUND TRACK SYSTEM (WITH SOFT CLOSE)

STAINLESS STEEL SIDE MOUNT ROUND TRACK SYSTEM

SKU	TRACK LENGTH
SLSS2-6	78 ³ / ₄ "
SLSS2-8	98 ⁷ / ₁₆ "

SKU	TRACK LENGTH
SLSS2-6-SC*	78 ³ / ₄ "
SLSS2-8-SC*	98 ⁷ / ₁₆ "

** Soft Close / Open Hardware is Included for Both Directions in Addition to the SLSS1-6 and SLSS1-8 Complete Kit Contents*

CROSS REFERENCE

NGP	SLSS1	SLSS2	SLSS1-6-SC	SLSS1-8-SC	SLSS2-6-SC	SLSS2-8-SC
PEMCO	W60	W100	SFT-W60	SFT-W60	SFT-W100	SFT-W100
HAGER	9432	9436	--	--	--	--
KN CROWDER	CRT-51	CRT-52	--	--	--	--

FIRE DOOR ACCESSORIES

UL CERTIFIED FOR USE IN
THE US AND CANADA



GAP90

Fire Door Head/
Jamb Gap Solution

- ▶ 1/8" - 3/8" Gaps on 60 & 90 Minute Doors
- ▶ 1/8" - 9/16" Gaps on 20 & 45 Minute Doors
- ▶ Non-Handed
- ▶ In-Field Modifiable
- ▶ Available in Dark Brown and Gray



GAP90N

Fire Door Head/
Jamb Gap Solution
for Narrow Stops

- ▶ 1/8" - 3/8" Gaps on 60 & 90 Minute Doors
- ▶ 1/8" - 9/16" Gaps on 20 & 45 Minute Doors
- ▶ For Use When the Soffit Depth is Between 1/2" and 1 3/8"
- ▶ Non-Handed
- ▶ In-Field Modifiable
- ▶ Available in Dark Brown and Gray



GAP90-ME

Meeting Edge
Gap Solution

- ▶ Meeting Edge Gaps (Pairs of Doors), up to 3/8"
- ▶ Non-Handed
- ▶ In-Field Modifiable
- ▶ Gray Finish



*See Installation Requirements.



9990

Fire Door Top
Gap Solution

- ▶ Door Top Gaps, Measuring up to 1/2"
- ▶ Non-Handed
- ▶ In-Field Modifiable
- ▶ Recommended for Doors with Parallel Arm Closers
- ▶ Brushed Stainless Steel Finish

FIRE DOOR ACCESSORIES

UL CERTIFIED FOR USE IN
THE US AND CANADA



9590 Fire Door Bottom Gap Solution

- ▶ Door Bottom Gaps, up to 1 1/2"
- ▶ Non-Handed
- ▶ In-Field Modifiable
- ▶ Brushed Stainless Steel Finish



9595DKB Floating Fire Door Bottom Gap Solution

- ▶ Door Bottom Gaps, up to 1 3/8"
- ▶ Non-Handed
- ▶ Designed to Travel Over Uneven Floors,
With a Range of 3/8"
- ▶ Optional L-Bracket Allows for Easy Installation
- ▶ Powder-Coated Matte-Black



HP90-MORT Mortise Hardware Prep Filler

*See Installation Requirements.



HP90-FB Flush Bolt Hardware Prep Filler

*See Installation Requirements.

GAPGUARD FIRE CAULK

- ▶ Fill up to a 1/2" Diameter Thru-Hole on 60 & 90 Minute Doors
- ▶ Fill up to a 1" Diameter Thru-Hole on 20 & 45 Minute Doors
- ▶ Fully-Cured in 24 Hours
- ▶ Sandable/Paintable
- ▶ Color: Tan
- ▶ 10.0 oz Cartridges, 10 per Box
- ▶ 3.0 oz. Tubes, 6 Tubes per Box



*To retain UL Certification, the products indicated must be installed using GapGuard Fire Caulk.



HP90-CYL Cylindrical Hardware Prep Filler

*See Installation Requirements.

Includes Steel Filler Plates for use on Hollow Metal Doors

GAPGUARD

FIRE DOOR ACCESSORIES

FP180-225 Frame Patch Kit

UL Certified for Steel Fire Doors and Frames Rated up to 3 Hours

Maximum Area of Cutout Concealed by Frame Patch is 2-1/2 Sq. In.



FR-180 Frame Patch Kit

UL Certified for Steel Fire Doors and Frames Rated up to 3 Hours

Available in 6" and 48" Sizes and may be Field Cut to Size.

(See Our Website for Maximum Patch Coverages)



9245V Intumescent Door Shoe with Vinyl Seal

UL Certified for Door Bottom Gaps — Measuring up to 1-1/2" and for up to 45 Minutes

Anodized (9245VA)
Black (9245VDKB)



9245WH Intumescent Door Shoe with Nylon Brush

UL Certified for Door Bottom Gaps — Measuring up to 1-1/2" and for up to 45 Minutes

Anodized (9245WHA)
Black (9245WHDKB)



GAP90 AND GAP90N Fire Door Head/Jamb Gap Solutions Up To 90 Minutes

YOU CAN NOW REMEDIATE:

- Up to 3/8" Excessive Clearance on 60- and 90-Minute Fire-Rated Openings
- Up to 9/16" Clearance 20- and 45 Minute



GAP90-ME Meeting Edge and Door Perimeter Gap Solution

EXCITING UPDATES:

- You can Now Remediate up to 3/8" Clearance at 90-Minute
- May be used on the Perimeter of a Hollow Metal Door Frame
- May be used on the Perimeter of Both Hollow Metal and Wood Doors. Wood Doors Require Fire Caulk.



9200 Gap Solution for Excessive Fire Door and Frame Clearances - Up to 45 Minutes

YOU CAN NOW REMEDIATE:

- Up to 3/8" Excessive Clearance on 20- and 45 Minute Fire-Rated Openings



GAPGUARD FIRE CAULK

Now Available in a Convenient 3.0 oz Tube
(Sold in a Six-Pack)





GAPGUARD

FIRE DOOR ACCESSORIES

NOW EVEN MORE

SOLUTIONS

TO GET YOUR EXISTING FIRE DOORS BACK INTO COMPLIANCE

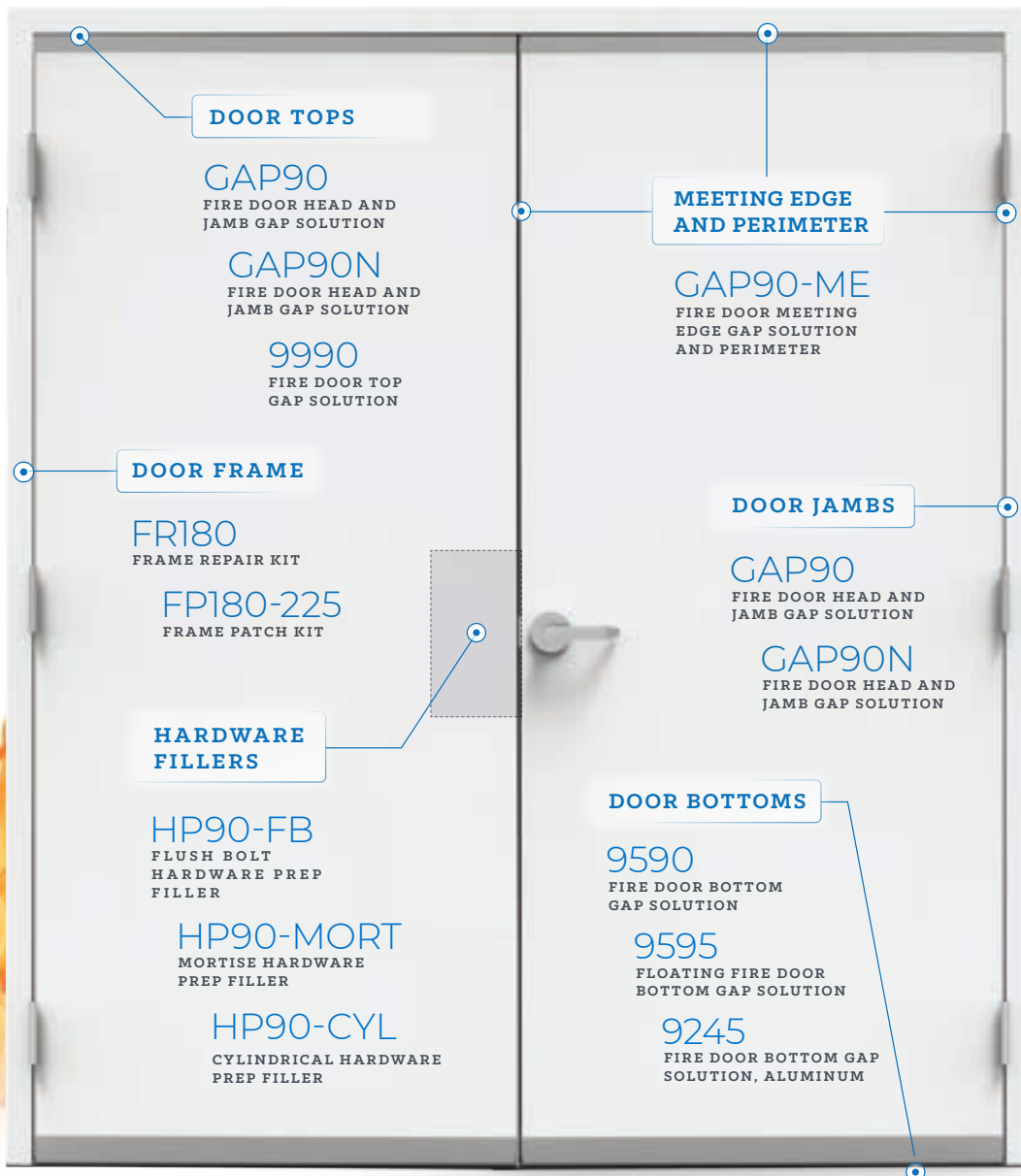

VISIT US ONLINE OR GIVE US A CALL TO LEARN HOW GAPGUARD CAN HELP YOU GET BACK INTO COMPLIANCE!



MEMPHIS | CARSON CITY

NATIONAL GUARD PRODUCTS, INC.

MEMPHIS

4985 East Raines Road
Memphis, TN 38118

CARSON CITY

3689 Arrowhead Drive
Carson City, NV 89706

Fax: (800) 255-7874

Email: info@ngp.com

Quotes: quotes@ngp.com

Orders: orders@ngp.com

ngp.com

1-800-NGP-RUSH



For Our Most Up-to-Date
Condensed Catalog Scan this
QR Code or Visit ngp.com.



For Our Most Up-To-Date
Complete Product Catalog Scan
this QR Code or Visit ngp.com.



ngp.com
1-800-NGP-RUSH

FAX: (800) 255-7874

QUOTES: quotes@ngp.com

ORDERS: orders@ngp.com

MEMPHIS

4985 East Raines Road
Memphis, TN 38118

CARSON CITY

3689 Arrowhead Drive
Carson City, NV 89706