

COMPANY:
 ACCOUNT#
 ADDRESS:
 ADDRESS:
 PHONE:
 FAX:
 CONTACT:

MONORAIL GASKETING
203N

FRONT AND TOP VIEW

REVISIONS			
REV.	DESCRIPTION	DATE	APPR'D
A	REDRAWN	9/24/07	

FRONT VIEW

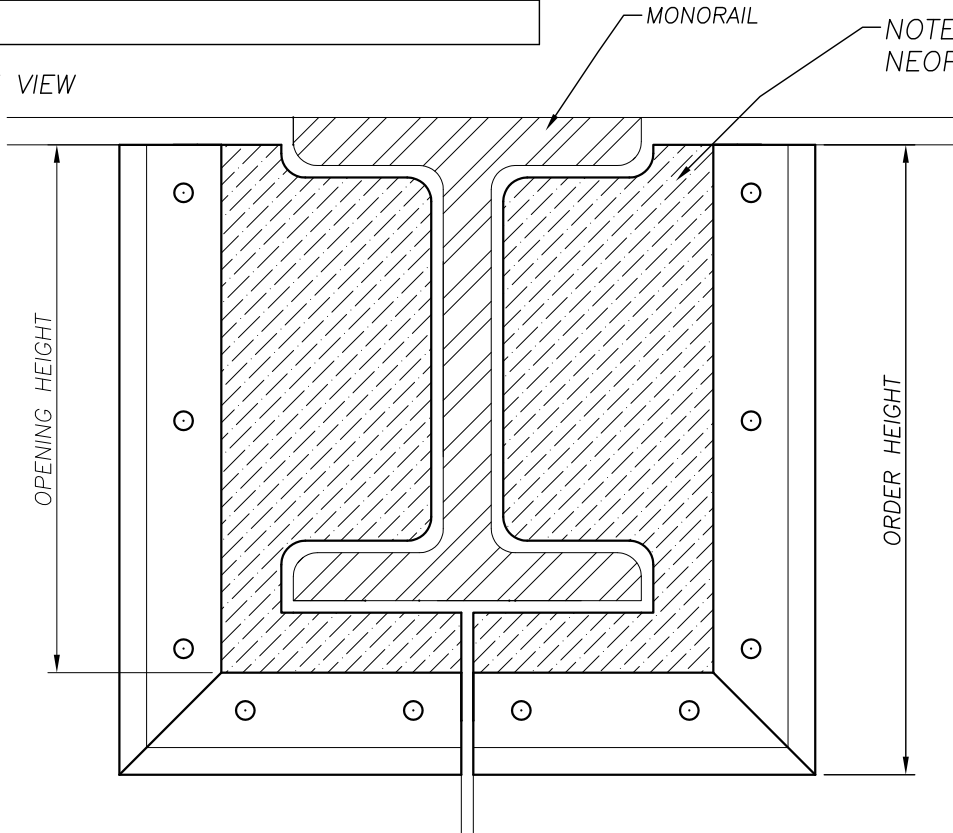

INFORMATION FOR ORDERING.
 OPENING WIDTH PLUS 2" = ORDER WIDTH.
 OPENING HEIGHT PLUS 1" = ORDER HEIGHT.
 NOTE: FULL NEOPRENE MATERIAL SUPPLIED FOR CUTTING IN FIELD.
 / ORDER WIDTH = _____
 / ORDER HEIGHT = _____

AVAILABLE FINISHES:
 A = CLEAR ALUMINUM
 B = GOLD
 DKB = DARK BRONZE

AVAILABLE GASKET:
 NEOPRENE (BLACK)

TOLERANCE = +/- 1/16"

TOP VIEW

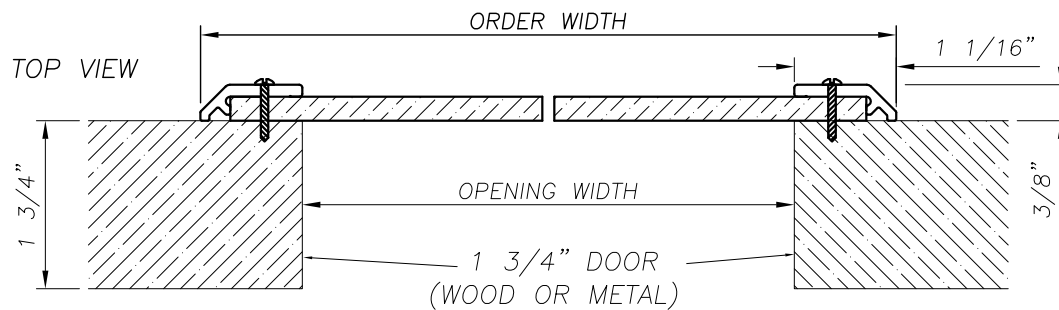

	NATIONAL GUARD PRODUCTS, INC. 4985 EAST RAINES ROAD MEMPHIS, TN 38118 PHONE (800) 647-7874 FAX (800) 255-7874			
	TITLE: MONORAIL GASKETING (203N)			
DRAWN BY: DANNY TOMPKINS	SIZE: A	FSCM NO.	DWG NO. 1	REV: A
SCALE: HALF		DATE: 9/24/07	SHEET: 1 OF 1	